

STERLING RANCH COLORADO METROPOLITAN DISTRICT NO. 5
8390 East Crescent Parkway, Suite 300
Greenwood Village, CO 80111
Phone 303-779-5710 Fax 303-779-0348

February 13, 2019

VIA EMAIL: KRider@douglas.co.us

Douglas County Clerk & Recorder
Attn: Clerk to the Board
301 Wilcox Street
Castle Rock, CO 80104

Re: 2017 Annual Report

To Whom It May Concern,

Please accept the enclosed as the 2017 annual report for Sterling Ranch Colorado Metropolitan District No. 5.

Please let me know if you have any questions.

Thank you,



Denise Denslow,
District Manager

Enclosures

Cc: Lisa Frizell, Douglas County Assessor via email (assessors@douglas.co.us)
Dave Gill, Douglas County Treasurer via email (dctreasurer@douglas.co.us)
State Auditor, Local Government Audit Division via email (osa.lg@state.co.us)
Division of Local Government via E-Filing Portal
MaryAnn McGeady, Esq.; McGeady Becher, P.C.
Board of Directors

Douglas County Special Districts
Annual Report and Disclosure Form

Name of the District	Sterling Ranch Colorado Metropolitan District No. 5; The organizational date for this District is December 10, 2013.
Report for Calendar Year	2017
(i) Annual Budget	The District's 2018 Adopted Budget is attached (see Exhibit A).
(ii) Annual Construction Schedule; Reconciliation of the Capital Improvement Program for Completion of the Improvements in the Following Two (2) Years	No construction by the District took place in 2017, however the Sterling Ranch Community Authority Board ("CAB"), of which the District is a member, undertook significant construction activity in 2017, including water, sewer, street, and park and recreation improvements.
(iii) Audited Financial Statements	The District's 2017 Audit Exemption is attached (see Exhibit B). The CAB has filed audited financial statements for 2017 with the State Auditor.
(iv) Total Debt Authorized; Total Debt Issued; Remaining Debt Authorized and Intended to be Issued	The District has \$23,400,000,000 in total debt authorization. The Service Plans for Sterling Ranch Colorado Metropolitan Districts 1-7 ("Districts") limit the aggregate amount of debt that the Districts can issue to \$1,800,000,000. No debt has yet been issued by the District. The CAB issued \$21,500,000 in Limited Tax Supported Revenue Senior Bonds and \$2,090,000 in Limited Tax Supported Revenue Subordinate Bonds in 2015. In 2016, the CAB issued its \$84,000,000 Taxable Subordinate Limited Revenue Promissory Note, Series 2016, and its \$21,000,000 Taxable Subordinate Limited Service Fee Revenue Promissory Note, Series 2016. In 2017, the CAB issued \$75,030,000 in Limited Tax Supported Revenue Senior Bonds and \$14,090,000 in Limited Tax Supported Revenue Subordinate Bonds.
(v) Names, Terms and Officers of the Board of Directors	James L. Yates , President Term Expires May 2020; Harold R. Smethills , Vice President/Treasurer Term Expires May 2020; Diane H. Smethills , Assistant Secretary Term Expires May 2022
(vi) Bylaw, Rules and Regulations Regarding Bidding, Conflict of Interest, Contracting and Other Governance Matters	The District currently has no bylaws or rules and regulations regarding governance matters, but the CAB has adopted rules and regulations regarding water and sewer service fees and charges
(vii) Current Intergovernmental Agreements and Amendments	The District entered into an intergovernmental agreement in 2017 amending its rules and regulations (see Exhibit C).
(viii) Summary of All Current Contracts for Services Related to Construction	The District did not enter into any contracts for services related to construction in 2017, but the CAB contracted for significant construction activity in 2017.

(ix) Current Approved Service Plan and Any Amendments

The District's Service Plan (approved August 27, 2013) was not amended in 2017 and was provided previously with the 2013 Annual Report.

EXHIBIT A
2018 Adopted Budget

LETTER OF BUDGET TRANSMITTAL

Date: January 29, 2018
To: Division of Local Government
1313 Sherman Street, Room 521
Denver, Colorado 80203

Attached are the 2018 budget and budget message for STERLING RANCH COLORADO METROPOLITAN DISTRICT NO. 5 in Douglas County, Colorado, submitted pursuant to Section 29-1-113, C.R.S. This budget was adopted on November 21, 2017. If there are any questions on the budget, please contact:

Denise Denslow, District Manager
CliftonLarsonAllen LLP
8390 E. Crescent Parkway, Suite 500
Greenwood Village, CO 80111
Telephone number: 303-779-4525
Denise.Denslow@claconnect.com

I, Denise Denslow, District Manager of the Sterling Ranch Colorado Metropolitan District No. 5 hereby certify that the attached is a true and correct copy of the 2018 budget.

By:



Denise Denslow, District Manager

RESOLUTION NO. 2017-11-02

RESOLUTION TO ADOPT BUDGET AND APPROPRIATE SUMS OF MONEY

RESOLUTION OF THE BOARD OF DIRECTORS OF
STERLING RANCH COLORADO METROPOLITAN DISTRICT NO. 5, DOUGLAS
COUNTY, COLORADO, PURSUANT TO SECTION 29-1-108, C.R.S., SUMMARIZING
EXPENDITURES AND REVENUES FOR EACH FUND, ADOPTING A BUDGET AND
APPROPRIATING SUMS OF MONEY FOR THE BUDGET YEAR 2018

A. The Board of Directors of Sterling Ranch Colorado Metropolitan District No. 5 (the "**District**") has appointed CliftonLarsonAllen LLP to prepare and submit a proposed budget to said governing body at the proper time.

B. CliftonLarsonAllen LLP has submitted a proposed budget to this governing body on October 11, 2017 for its consideration.

C. Upon due and proper notice, published or posted in accordance with the law, said proposed budget was open for inspection by the public at a designated place, a public hearing was held on November 21, 2017, and interested taxpayers were given the opportunity to file or register any objections to said proposed budget.

D. The budget has been prepared to comply with all terms, limitations and exemptions, including, but not limited to, reserve transfers and expenditure exemptions, under Article X, Section 20 of the Colorado Constitution ("**TABOR**") and other laws or obligations which are applicable to or binding upon the District.

E. Whatever increases may have been made in the expenditures, like increases were added to the revenues so that the budget remains in balance, as required by law.

F. The Board of Directors has made provision therein for revenues in an amount equal to or greater than the total proposed expenditures as set forth in said budget.

G. It is not only required by law, but also necessary to appropriate the revenues provided in the budget to and for the purposes described below, thereby establishing a limitation on expenditures for the operations of the District.

NOW, THEREFORE, BE IT RESOLVED BY THE BOARD OF DIRECTORS OF
STERLING RANCH COLORADO METROPOLITAN DISTRICT NO. 5, DOUGLAS
COUNTY, COLORADO:

1. The budget, as submitted, amended, and summarized by fund, is hereby approved and adopted as the budget of the District for the year stated above.

2. The budget is hereby approved and adopted, shall be certified by the Secretary of the District to all appropriate agencies and is made a part of the public records of the District.

3. The sums set forth as the total expenditures of each fund in the budget attached hereto as Exhibit A and incorporated herein by reference are hereby appropriated from the revenues of each fund, within each fund, for the purposes stated.

[SIGNATURE PAGE FOLLOWS]

**[SIGNATURE PAGE TO RESOLUTION TO ADOPT BUDGET AND
APPROPRIATE SUMS OF MONEY]**

RESOLUTION APPROVED AND ADOPTED on November 21, 2017.

**STERLING RANCH COLORADO
METROPOLITAN DISTRICT NO. 5**

By: 
President

Attest:
By: 
Secretary



EXHIBIT A

Budget



CliftonLarsonAllen LLP
www.CLAconnect.com

Accountant's Compilation Report

Board of Directors
Sterling Ranch Colorado Metropolitan District No. 5
Douglas County, Colorado

Management is responsible for the accompanying budget of revenues, expenditures, and fund balances of Sterling Ranch Colorado Metropolitan District No. 5 for the year ending December 31, 2018, including the estimate of comparative information for the year ending December 31, 2017, and the actual comparative information for the year ending December 31, 2016, in the format prescribed by Colorado Revised Statutes (C.R.S.) 29-1-105. We have performed a compilation engagement in accordance with Statements on Standards for Accounting and Review Services promulgated by the Accounting and Review Services Committee of the American Institute of Certified Public Accountants. We did not audit or review the budget nor were we required to perform any procedures to verify the accuracy or completeness of the information provided by management. Accordingly, we do not express an opinion, a conclusion, nor provide any form of assurance on the accompanying budget.

We draw attention to the summary of significant assumptions which describe that the budget is presented in accordance with the requirements of C.R.S. 29-1-105, and is not intended to be a presentation in accordance with accounting principles generally accepted in the United States of America.

We are not independent with respect to Sterling Ranch Colorado Metropolitan District No. 5.

CliftonLarsonAllen LLP

Greenwood Village, Colorado
January 11, 2018



An independent member of Nexia International

STERLING RANCH COLORADO METROPOLITAN DISTRICT NO. 5
GENERAL FUND
2018 BUDGET AS ADOPTED
WITH 2016 ACTUAL AND 2017 ESTIMATED
For the Years Ended and Ending December 31,

1/11/2018

	ACTUAL 2016	ESTIMATED 2017	ADOPTED 2018
BEGINNING FUND BALANCES	\$ -	\$ -	\$ -
REVENUES			
Total revenues	-	-	-
Total funds available	-	-	-
EXPENDITURES			
Total expenditures	-	-	-
Total expenditures and transfers out requiring appropriation	-	-	-
ENDING FUND BALANCES	\$ -	\$ -	\$ -

This financial information should be read only in connection with the accompanying accountant's compilation report and summary of significant assumptions.

STERLING RANCH COLORADO METROPOLITAN DISTRICT NO. 5
PROPERTY TAX SUMMARY INFORMATION
For the Years Ended and Ending December 31,

1/11/2018

	ACTUAL 2016	ESTIMATED 2017	ADOPTED 2018
ASSESSED VALUATION - DOUGLAS			
Certified Assessed Value	\$	-	\$
	-	-	\$
	-	-	\$
MILL LEVY			
PROPERTY TAXES			
Budgeted Property Taxes	\$	-	\$
	-	-	\$
	-	-	\$
BUDGETED PROPERTY TAXES			
	\$	-	\$
	-	-	\$
	-	-	\$

This financial information should be read only in connection with the accompanying accountant's compilation report and summary of significant assumptions.

STERLING RANCH COLORADO METROPOLITAN DISTRICT NO. 5
2018 BUDGET
SUMMARY OF SIGNIFICANT ASSUMPTIONS

Services Provided

The District, a quasi-municipal corporation and a political subdivision of the State of Colorado, was organized by order and decree of the District Court on December 10, 2013, and is governed pursuant to provisions of the Colorado Special District Act (Title 32, Article 1, Colorado Revised Statutes). The District's service area is located entirely within Douglas County, Colorado.

The District was established to provide for the design, planning, acquisition, construction, financing, relocation, installation, completion, operation, maintenance, and repair or replacement of public improvements and services, including streets, park and recreation, water, sanitary and storm sewer, public transportation, mosquito control, traffic and safety controls, fire protection, and television relay and translation. Under its Service Plan, the District was organized in conjunction with six other related Districts: Sterling Ranch Colorado Metropolitan District Nos. 1 through 4 and 6 through 7. Sterling Ranch Colorado Metropolitan District No. 1 serves as a Management District and Sterling Ranch Colorado Metropolitan District Nos. 2 through 7 serve as Financing Districts (collectively, the "Districts"). The Districts entered into a Community Authority Board Establishment Agreement (the "CABEA"), on January 6, 2014, which establishes the Sterling Ranch Community Authority Board (the "CAB"). The CAB will own, operate and maintain certain public improvements within the boundaries of the Districts.

On November 5, 2013, District voters authorized a total indebtedness of \$16,200,000,000 for the above listed facilities, excluding operations and maintenance, intergovernmental agreements, and debt refunding. In the same election, the District voters approved an annual increase in property taxes of \$50,000,000 (without limitation to rate) and an annual increase in fees and charges of \$50,000,000 (without limitation to rate) to pay operations and maintenance and capital costs. The District voters also authorized the District to collect, receive, retain and spend the full amount of all taxes and all other revenues in excess of TABOR spending, revenue raising or other limitations. On November 4, 2014, the District voters authorized an additional indebtedness of \$1,800,000,000 for a total indebtedness of \$18,000,000,000.

The Service Plans for District Nos. 1 – 7 limit the aggregate amount of debt that they may issue together with any debt issued by the CAB to \$1,800,000,000.

The District currently has no employees and all administrative functions are contracted.

The District prepares its budget on the modified accrual basis of accounting in accordance with the requirements of Colorado Revised Statutes C.R.S. 29-1-105.

Revenues and Expenditures

The District anticipates no financial activity in 2018.

Debt and Leases

The District has no outstanding debt, nor any operating or capital leases.

This information is an integral part of the accompanying budget.

I, Denise Denslow, hereby certify that I am the duly appointed Secretary of the Sterling Ranch Colorado Metropolitan District No. 5, and that the foregoing is a true and correct copy of the budget for the budget year 2018, duly adopted at a meeting of the Board of Directors of the Sterling Ranch Colorado Metropolitan District No. 5 held on November 21, 2017.



Secretary



CERTIFICATION OF TAX LEVIES for NON-SCHOOL Governments

TO: County Commissioners¹ of Douglas County, Colorado.

On behalf of the Sterling Ranch Colorado Metro District 5,
(taxing entity)^A

the Board of Directors,
(governing body)^B

of the Sterling Ranch Colorado Metro District 5,
(local government)^C

Hereby officially certifies the following mills to be levied against the taxing entity's GROSS \$ 0 assessed valuation of: (GROSS^D assessed valuation, Line 2 of the Certification of Valuation Form DLG 57^E)

Note: If the assessor certified a NET assessed valuation (AV) different than the GROSS AV due to a Tax Increment Financing (TIF) Area^F the tax levies must be calculated using the NET AV. The taxing entity's total property tax revenue will be derived from the mill levy multiplied against the NET assessed valuation of: \$ 0 (NET^G assessed valuation, Line 4 of the Certification of Valuation Form DLG 57)
USE VALUE FROM FINAL CERTIFICATION OF VALUATION PROVIDED BY ASSESSOR NO LATER THAN DECEMBER 10

Submitted: 12/08/2017 for budget/fiscal year 2018.
(no later than Dec. 15) (mm/dd/yyyy) (yyyy)

PURPOSE (see end notes for definitions and examples)	LEVY ²	REVENUE ²
1. General Operating Expenses ^H	0.000 mills	\$ 0
2. <Minus> Temporary General Property Tax Credit/ Temporary Mill Levy Rate Reduction ^I	< > mills	\$ < >
SUBTOTAL FOR GENERAL OPERATING:	0.000 mills	\$ 0
3. General Obligation Bonds and Interest ^J	mills	\$
4. Contractual Obligations ^K	mills	\$
5. Capital Expenditures ^L	mills	\$
6. Refunds/Abatements ^M	mills	\$
7. Other ^N (specify): _____	mills	\$
_____	mills	\$
TOTAL: [Sum of General Operating Subtotal and Lines 3 to 7]	0.000 mills	\$ 0

Contact person: Gigi Pangindian Daytime phone: 303-779-5710
(print)

Signed: *Gigi Pangindian* Title: Accountant for the District

Include one copy of this tax entity's completed form when filing the local government's budget by January 31st, per 29-1-113 C.R.S., with the Division of Local Government (DLG), Room 521, 1313 Sherman Street, Denver, CO 80203. Questions? Call DLG at (303) 864-7720.

¹ If the taxing entity's boundaries include more than one county, you must certify the levies to each county. Use a separate form for each county and certify the same levies uniformly to each county per Article X, Section 3 of the Colorado Constitution.
² Levies must be rounded to three decimal places and revenue must be calculated from the total NET assessed valuation (Line 4 of Form DLG57 on the County Assessor's **FINAL** certification of valuation).

CERTIFICATION OF TAX LEVIES, continued

THIS SECTION APPLIES TO TITLE 32, ARTICLE 1 SPECIAL DISTRICTS THAT LEVY TAXES FOR PAYMENT OF GENERAL OBLIGATION DEBT (32-1-1603 C.R.S.). Taxing entities that are Special Districts or Subdistricts of Special Districts must certify separate mill levies and revenues to the Board of County Commissioners, one each for the funding requirements of each debt (32-1-1603, C.R.S.) Use additional pages as necessary. The Special District's or Subdistrict's total levies for general obligation bonds and total levies for contractual obligations should be recorded on Page 1, Lines 3 and 4 respectively.

CERTIFY A SEPARATE MILL LEVY FOR EACH BOND OR CONTRACT:

BONDS^J:

1. Purpose of Issue: _____
Series: _____
Date of Issue: _____
Coupon Rate: _____
Maturity Date: _____
Levy: _____
Revenue: _____

2. Purpose of Issue: _____
Series: _____
Date of Issue: _____
Coupon Rate: _____
Maturity Date: _____
Levy: _____
Revenue: _____

CONTRACTS^K:

3. Purpose of Contract: _____
Title: _____
Date: _____
Principal Amount: _____
Maturity Date: _____
Levy: _____
Revenue: _____

4. Purpose of Contract: _____
Title: _____
Date: _____
Principal Amount: _____
Maturity Date: _____
Levy: _____
Revenue: _____

Use multiple copies of this page as necessary to separately report all bond and contractual obligations per 32-1-1603, C.R.S.

NOTICE AS TO PROPOSED 2018 BUDGETS AND AMENDMENT OF 2017 BUDGETS

STERLING RANCH COLORADO METROPOLITAN DISTRICT NOS. 1 - 7 DOUGLAS COUNTY, COLORADO

NOTICE IS HEREBY GIVEN, pursuant to Sections 29-1-108 and 109, C.R.S., that proposed budgets have been submitted to the Board of Directors of the Sterling Ranch Colorado Metropolitan District Nos. 1 - 7 (the "Districts") for the ensuing year of 2018. The necessity may also arise for amendments of the 2017 budgets of the Districts. Copies of the proposed 2018 budgets and 2017 amended budgets (if appropriate) are on file in the office of the Districts' Accountant, CliftonLarsonAllen LLP, 8390 E. Crescent Pkwy., Suite 500, Greenwood Village, CO 80111, where same are available for public inspection. Such proposed 2018 budgets and 2017 amended budgets will be considered at a regular meeting of the Districts to be held on a First Reading at 3:00 p.m. on October 17, 2017 at the offices of CliftonLarsonAllen LLP, 8390 E. Crescent Pkwy., Suite 500, Greenwood Village, CO 80111, and for a Second and Final Reading and public hearing to be held at 3:00 p.m. at a regular meeting on November 21, 2017 at the offices of CliftonLarsonAllen LLP, 8390 E. Crescent Pkwy., Suite 500, Greenwood Village, CO 80111. Any interested elector within the Districts may, at any time prior to the final adoption of the 2018 budgets or the 2017 amended budgets, inspect the 2018 budgets and the 2017 amended budgets and file or register any objections thereto. The address of the office of the Districts where the names and addresses of the Districts' Board Members and their officers and the address, telephone number, fax number and email address of the Districts may be obtained is: c/o CliftonLarsonAllen LLP, 8390 E. Crescent Pkwy., Suite 500, Greenwood Village, Colorado 80111.

AFFIDAVIT OF PUBLICATION

State of Colorado)ss County of Douglas

This Affidavit of Publication for the Douglas County News Press, a weekly newspaper, printed and published for the County of Douglas, State of Colorado, hereby certifies that the attached legal notice was published in said newspaper once in each week, for 1 successive week(s), the last of which publication was made the 12th day of October A.D., 2017, and that copies of each number of said paper in which said Public Notice was published were delivered by carriers or transmitted by mail to each of the subscribers of said paper, according to their accustomed mode of business in this office.

[Handwritten signature]

for the Douglas County News Press

State of Colorado) County of Douglas)ss

The above Affidavit and Certificate of Publication was subscribed and sworn to before me by the above named Gerard Healey, publisher of said newspaper, who is personally known to me to be the identical person in the above certificate on 12th day of October A.D., 2017. Gerard Healey has verified to me that he has adopted an electronic signature to function as his signature on this document.

STERLING RANCH COLORADO METROPOLITAN DISTRICT NOS. 1 - 7

/s/ Denise Denslow, District Manager

Legal Notice No.: 931749 First Publication: October 12, 2017 Last Publication: October 12, 2017 Publisher: Douglas County News-Press

[Handwritten signature]

HEATHER L. CROMPTON NOTARY PUBLIC STATE OF COLORADO NOTARY ID 20154048391 Commission expiration date: December 18, 2019

My Commission Expires 12/18/19

Notary Public

NOTICE AS TO PROPOSED 2018 BUDGETS AND AMENDMENT OF 2017 BUDGETS

STERLING RANCH COLORADO METROPOLITAN DISTRICT NOS. 1 - 7 DOUGLAS COUNTY, COLORADO

AFFIDAVIT OF PUBLICATION

NOTICE IS HEREBY GIVEN, pursuant to Sections 29-1-108 and 109, C.R.S., that proposed budgets have been submitted to the Board of Directors of the Sterling Ranch Colorado Metropolitan District Nos. 1 - 7 (the "Districts") for the ensuing year of 2018. The necessity may also arise for amendments of the 2017 budgets of the Districts. Copies of the proposed 2018 budgets and 2017 amended budgets (if appropriate) are on file in the office of the Districts' Accountant, CliftonLarsonAllen LLP, 8390 E. Crescent Pkwy., Suite 500, Greenwood Village, CO 80111, where same are available for public inspection. Such proposed 2018 budgets and 2017 amended budgets will be considered at a regular meeting to be held at the offices of CliftonLarsonAllen LLP, 8390 E. Crescent Pkwy., Suite 500, Greenwood Village, CO 80111 at 3:00 p.m. on November 21, 2017. Any interested elector within the Districts may, at any time prior to the final adoption of the 2018 budgets or the 2017 amended budgets, inspect the 2018 budgets and the 2017 amended budgets and file or register any objections thereto.

State of Colorado)ss
County of Douglas

This Affidavit of Publication for the Douglas County News Press, a weekly newspaper, printed and published for the County of Douglas, State of Colorado, hereby certifies that the attached legal notice was published in said newspaper once in each week, for 1 successive week(s), the last of which publication was made the 9th day of November A.D., 2017, and that copies of each number of said paper in which said Public Notice was published were delivered by carriers or transmitted by mail to each of the subscribers of said paper, according to their accustomed mode of business in this office.

[Handwritten signature]

STERLING RANCH COLORADO METROPOLITAN DISTRICT NOS. 1 - 7

/s/ Denise Denslow
District Manager

Legal Notice No.: 931966
First Publication: November 9, 2017
Last Publication: November 9, 2017
Publisher: Douglas County News-Press

for the Douglas County News Press
State of Colorado)
County of Douglas)ss

The above Affidavit and Certificate of Publication was subscribed and sworn to before me by the above named Gerard Healey, publisher of said newspaper, who is personally known to me to be the identical person in the above certificate on 9th day of November A.D., 2017. Gerard Healey has verified to me that he has adopted an electronic signature to function as his signature on this document.

[Handwritten signature]

HEATHER L. CROMPTON
NOTARY PUBLIC
STATE OF COLORADO
NOTARY ID 20154048391
Commission expiration date:
December 18, 2019

My Commission Expires 12/18/19

Notary Public

EXHIBIT B
2017 Audit Exemption

APPLICATION FOR EXEMPTION FROM AUDIT

SHORT FORM

NAME OF GOVERNMENT ADDRESS Sterling Ranch Colorado Metropolitan District No. 5
 8390 E Crescent Parkway
 Suite 500
 Greenwood Village, CO 80111
CONTACT PERSON Gigi Pangindian
PHONE 303-779-5710
EMAIL Gigi.Pangindian@claconnect.com
FAX 303-779-0348

For the Year Ended
 12/31/17
 or fiscal year ended:

PART 1 - CERTIFICATION OF PREPARER

I certify that I am skilled in governmental accounting and that the information in the application is complete and accurate, to the best of my knowledge.

NAME: Gigi Pangindian
TITLE Accountant for the District
FIRM NAME (if applicable) CliftonLarsonAllen LLP
ADDRESS 8390 E Crescent Parkway, Suite 500, Greenwood Village, CO 80111
PHONE 303-779-5710
DATE PREPARED
 (Must be prepared prior to Board approval) 2/15/2018

PREPARER (SIGNATURE REQUIRED)

SEE ATTACHED ACCOUNTANT'S COMPILATION REPORT

Please indicate whether the following financial information is recorded using Governmental or Proprietary fund types	GOVERNMENTAL <small>(MODIFIED ACCRUAL BASIS)</small>	PROPRIETARY <small>(CASH OR BUDGETARY BASIS)</small>
	<input checked="" type="checkbox"/>	<input type="checkbox"/>

PART 2 - REVENUE

REVENUE: All revenues for all funds must be reflected in this section, including proceeds from the sale of the government's land, building, and equipment, and proceeds from debt or lease transactions. Financial information will not include fund equity information.

Line#	Description	Round to nearest Dollar	
2-1	Taxes: Property	\$ -	Please use this space to provide any necessary explanations
2-2	Specific ownership	\$ -	
2-3	Sales and use	\$ -	
2-4	Other (specify):	\$ -	
2-5	Licenses and permits	\$ -	
2-6	Intergovernmental: Grants	\$ -	
2-7	Conservation Trust Funds (Lottery)	\$ -	
2-8	Highway Users Tax Funds (HUTF)	\$ -	
2-9	Other (specify):	\$ -	
2-10	Charges for services	\$ -	
2-11	Fines and forfeits	\$ -	
2-12	Special assessments	\$ -	
2-13	Investment income	\$ -	
2-14	Charges for utility services	\$ -	
2-15	Debt proceeds (should agree with line 4-4, column 2)	\$ -	
2-16	Lease proceeds	\$ -	
2-17	Developer Advances received (should agree with line 4-4)	\$ -	
2-18	Proceeds from sale of capital assets	\$ -	
2-19	Fire and police pension	\$ -	
2-20	Donations	\$ -	
2-21	Other (specify):	\$ -	
2-22		\$ -	
2-23		\$ -	
2-24	(add lines 2-1 through 2-23) TOTAL REVENUE	\$ -	

PART 3 - EXPENDITURES

EXPENDITURES: All expenditures for all funds must be reflected in this section, including the purchase of capital assets and principal and interest payments on long-term debt. Financial information will not include fund equity information.

Line#	Description	Round to nearest Dollar	
3-1	Administrative	\$ -	Please use this space to provide any necessary explanations
3-2	Salaries	\$ -	
3-3	Payroll taxes	\$ -	
3-4	Contract services	\$ -	
3-5	Employee benefits	\$ -	
3-6	Insurance	\$ -	
3-7	Accounting and legal fees	\$ -	
3-8	Repair and maintenance	\$ -	
3-9	Supplies	\$ -	
3-10	Utilities and telephone	\$ -	
3-11	Fire/Police	\$ -	
3-12	Streets and highways	\$ -	
3-13	Public health	\$ -	
3-14	Culture and recreation	\$ -	
3-15	Utility operations	\$ -	
3-16	Capital outlay	\$ -	
3-17	Debt service principal (should agree with Part 4)	\$ -	
3-18	Debt service interest	\$ -	
3-19	Repayment of Developer Advance Principal (should agree with line 4-4)	\$ -	
3-20	Repayment of Developer Advance Interest	\$ -	
3-21	Contribution to pension plan (should agree to line 7-2)	\$ -	
3-22	Contribution to Fire & Police Pension Assoc. (should agree to line 7-2)	\$ -	
3-23	Other (specify):	\$ -	
3-24		\$ -	
3-25		\$ -	
3-26	(add lines 3-1 through 3-24) TOTAL EXPENDITURES	\$ -	

If TOTAL REVENUE (Line 2-24) or TOTAL EXPENDITURES (Line 3-26) are GREATER than \$100,000 - **STOP**. You may not use this form. Please use the "Application for Exemption from Audit - LONG FORM".

PART 4 - DEBT OUTSTANDING, ISSUED, AND RETIRED

Please answer the following questions by marking the appropriate boxes.

- | | | Yes | No |
|-----|---|--------------------------|-------------------------------------|
| 4-1 | Does the entity have outstanding debt?
If Yes, please attach a copy of the entity's Debt Repayment Schedule. | <input type="checkbox"/> | <input checked="" type="checkbox"/> |

- | | | | |
|-----|--|--------------------------|-------------------------------------|
| 4-2 | Is the debt repayment schedule attached? If no, MUST explain:
<div style="border: 1px solid black; padding: 2px; min-height: 20px;">N/A</div> | <input type="checkbox"/> | <input checked="" type="checkbox"/> |
|-----|--|--------------------------|-------------------------------------|

- | | | | |
|-----|---|--------------------------|-------------------------------------|
| 4-3 | Is the entity current in its debt service payments? If no, MUST explain:
<div style="border: 1px solid black; padding: 2px; min-height: 20px;">The District has no outstanding debt.</div> | <input type="checkbox"/> | <input checked="" type="checkbox"/> |
|-----|---|--------------------------|-------------------------------------|

Please complete the following debt schedule, if applicable: (please only include principal amounts)(enter all amount as positive numbers)	Outstanding at end of prior year*	Issued during year	Retired during year	Outstanding at year-end
General obligation bonds	\$ -	\$ -	\$ -	\$ -
Revenue bonds	\$ -	\$ -	\$ -	\$ -
Notes/Loans	\$ -	\$ -	\$ -	\$ -
Leases	\$ -	\$ -	\$ -	\$ -
Developer Advances	\$ -	\$ -	\$ -	\$ -
Other (specify):	\$ -	\$ -	\$ -	\$ -
TOTAL	\$ -	\$ -	\$ -	\$ -

*must tie to prior year ending balance

Please answer the following questions by marking the appropriate boxes.

- | | | Yes | No |
|-----|--|-------------------------------------|--------------------------|
| 4-5 | Does the entity have any authorized, but unissued, debt? | <input checked="" type="checkbox"/> | <input type="checkbox"/> |

If yes: How much? \$ 21,600,000,000.00

Date the debt was authorized: 11/5/2013

- | | | | |
|-----|---|--------------------------|-------------------------------------|
| 4-6 | Does the entity intend to issue debt within the next calendar year? | <input type="checkbox"/> | <input checked="" type="checkbox"/> |
|-----|---|--------------------------|-------------------------------------|

If yes: How much? \$ -

- | | | | |
|-----|--|--------------------------|-------------------------------------|
| 4-7 | Does the entity have debt that has been refinanced that it is still responsible for? | <input type="checkbox"/> | <input checked="" type="checkbox"/> |
|-----|--|--------------------------|-------------------------------------|

If yes: What is the amount outstanding? \$ -

- | | | | |
|-----|--|--------------------------|-------------------------------------|
| 4-8 | Does the entity have any lease agreements? | <input type="checkbox"/> | <input checked="" type="checkbox"/> |
|-----|--|--------------------------|-------------------------------------|

If yes: What is being leased?

What is the original date of the lease?

Number of years of lease?

- | | | | |
|--|---|--------------------------|--------------------------|
| | Is the lease subject to annual appropriation? | <input type="checkbox"/> | <input type="checkbox"/> |
|--|---|--------------------------|--------------------------|

What are the annual lease payments? \$ -

- | | | | |
|-----|---|--------------------------|-------------------------------------|
| 4-9 | Does the entity have a certified Mill Levy? | <input type="checkbox"/> | <input checked="" type="checkbox"/> |
|-----|---|--------------------------|-------------------------------------|

If yes: Please provide the following mills levied for the year reported (do not report \$ amounts):

Bond Redemption	-
General/Other	-
TOTAL	-

Please use this space to provide any explanations or comments:

PART 5 - CASH AND INVESTMENTS

Please provide the entity's cash deposit and investment balances.

	Amount	Total
5-1 YEAR-END Total of ALL Checking and Savings Accounts	\$ -	
5-2 Certificates of deposit	\$ -	
Total Cash Deposits		\$ -
Investments (if investment is a mutual fund, please list underlying investments):		
	\$ -	
	\$ -	
5-3	\$ -	
	\$ -	
Total Investments		\$ -
Total Cash and Investments		\$ -

Please answer the following questions by marking in the appropriate boxes

- | | | Yes | No | N/A |
|-----|---|--------------------------|--------------------------|-------------------------------------|
| 5-4 | Are the entity's investments legal in accordance with Section 24-75-601, et. seq., C.R.S.? | <input type="checkbox"/> | <input type="checkbox"/> | <input checked="" type="checkbox"/> |
| 5-5 | Are the entity's deposits in an eligible (Public Deposit Protection Act) public depository (Section 11-10.5-101, et seq. C.R.S.)? | <input type="checkbox"/> | <input type="checkbox"/> | <input checked="" type="checkbox"/> |

If no, MUST use this space to provide any explanations:

PART 6 - CAPITAL ASSETS

Please answer the following questions by marking in the appropriate boxes.

Yes No

- 6-1 Does the entity have capital assets? Yes No
- 6-2 Has the entity performed an annual inventory of capital assets in accordance with Section 29-1-506, C.R.S.? If no, MUST explain: Yes No

The District has no capital assets.

Complete the following capital assets table:	Balance - beginning of the year*	Additions (Must be included in Part 3)	Deletions	Year-End Balance
Land	\$ -	\$ -	\$ -	\$ -
Buildings	\$ -	\$ -	\$ -	\$ -
Machinery and equipment	\$ -	\$ -	\$ -	\$ -
Furniture and fixtures	\$ -	\$ -	\$ -	\$ -
Construction In Progress (CIP)	\$ -	\$ -	\$ -	\$ -
Other (explain):	\$ -	\$ -	\$ -	\$ -
Accumulated Depreciation (Please enter a negative, or credit, balance)	\$ -	\$ -	\$ -	\$ -
TOTAL	\$ -	\$ -	\$ -	\$ -

*must tie to prior year ending balance

Please use this space to provide any explanations or comments:

PART 7 - PENSION INFORMATION

Please answer the following questions by marking in the appropriate boxes.

Yes No

- 7-1 Does the entity have an "old hire" firemen's pension plan? Yes No
- 7-2 Does the entity have a volunteer firemen's pension plan? Yes No

If yes: Who administers the plan?

Indicate the contributions from:

Tax (property, SO, sales, etc.):	\$ -
State contribution amount:	\$ -
Other (gifts, donations, etc.):	\$ -
TOTAL	\$ -

What is the monthly benefit paid for 20 years of service per retiree as of Jan 1? \$ -

Please use this space to provide any explanations or comments:

PART 8 - BUDGET INFORMATION

Please answer the following questions by marking in the appropriate boxes.

Yes No N/A

- 8-1 Did the entity file a budget with the Department of Local Affairs for the current year in accordance with Section 29-1-113 C.R.S.? Yes No N/A
- If no, MUST explain:

- 8-2 Did the entity pass an appropriations resolution, in accordance with Section 29-1-108 C.R.S.? If no, MUST explain: Yes No N/A

If yes: Please indicate the amount appropriated for each fund for the year reported:

General Fund	\$ -

PART 9 - TAXPAYER'S BILL OF RIGHTS (TABOR)

Please answer the following question by marking in the appropriate box

		Yes	No
9-1	Is the entity in compliance with all the provisions of TABOR [State Constitution, Article X, Section 20(5)]?	<input checked="" type="checkbox"/>	<input type="checkbox"/>

Note: An election to exempt the government from the spending limitations of TABOR does not exempt the government from the 3 percent emergency reserve requirement. All governments should determine if they meet this requirement of TABOR

If no, MUST explain:

PART 10 - GENERAL INFORMATION

Please answer the following questions by marking in the appropriate boxes.

		Yes	No
10-1	Is this application for a newly formed governmental entity? If yes: Date of formation: <input style="width: 400px;" type="text"/>	<input type="checkbox"/>	<input checked="" type="checkbox"/>
10-2	Has the entity changed its name in the past or current year? If yes: Please list the NEW name & PRIOR name: <input style="width: 500px;" type="text"/>	<input type="checkbox"/>	<input checked="" type="checkbox"/>
10-3	Is the entity a metropolitan district? Please indicate what services the entity provides: <input style="width: 500px;" type="text"/> Streets, water, storm drainage, sanitation, parks and recreation, transportation, mosquito control, television translation and relay, fire protection, and covenant enforcement.	<input checked="" type="checkbox"/>	<input type="checkbox"/>
10-4	Does the entity have an agreement with another government to provide services? If yes: List the name of the other governmental entity and the services provided: <input style="width: 500px;" type="text"/> Please see below.	<input checked="" type="checkbox"/>	<input type="checkbox"/>
10-5	Has the district filed a <i>Title 32, Article 1 Special District Notice of Inactive Status</i> during the year? [Applicable to Title 32 special districts only, pursuant to Sections 32-1-103 (9.3) and 32-1-104 (3), C.R.S.] If yes: Date Filed: <input style="width: 300px;" type="text"/>	<input type="checkbox"/>	<input checked="" type="checkbox"/>

Please use this space to provide any explanations or comments:

10-4: The District operates in conjunction with Sterling Ranch Colorado Metropolitan District Nos. 1-4, 6-7 and Sterling Ranch Community Authority Board (CAB). District Nos. 1-7 are the Taxing Districts and CAB is the Operating Authority.

PART 11 - GOVERNING BODY APPROVAL

Please answer the following question by marking in the appropriate box

YES

NO

12-1 Have you read the new Electronic Signature Policy and do you plan on submitting signatures in accordance with this policy?

Office of the State Auditor — Local Government Division - Exemption Form Electronic Signatures Policy and Procedure

Policy - Requirements

The Office of the State Auditor Local Government Audit Division may accept an electronic submission of an application for exemption from audit that includes governing board signatures obtained through a program such as DocuSign or Echosign. Required elements and safeguards are as follows:

- The preparer of the application is responsible for obtaining board signatures that comply with the requirement in Section 29-1-604 (3), C.R.S., that states the application shall be personally reviewed, approved, and signed by a majority of the members of the governing body.
- The application must be accompanied by the signature history document created by the electronic signature software. The signature history document must show when the document was created and when the document was emailed to the various parties, and include the dates the individual board members signed the document. The signature history must also show the individuals' email addresses and IP address.
- Office of the State Auditor staff will not coordinate obtaining signatures.

The application for exemption from audit form created by our office includes a section for governing body approval. Local governing boards note their approval and submit the application through one of the following three methods:

- 1) Submit the application in hard copy via the US Mail including original signatures.
- 2) Submit the application electronically via email and either,
 - a. Include a copy of an adopted resolution that documents formal approval by the Board, or
 - b. Include electronic signatures obtained through a software program such as DocuSign or Echosign in accordance with the requirements noted above.

Print the names of ALL current governing board members below.

A MAJORITY of the governing board members must complete and sign in the column below.

Board Member 1	Print Board Member's Name Diane H. Smethills	I, Diane H. Smethills, attest I am a duly elected or appointed board member, and that I have personally reviewed and approve this application for exemption from audit. Signed <u><i>Diane H. Smethills</i></u> Date: <u>3/20/18</u> My term Expires: May 2018
Board Member 2	Print Board Member's Name James L. Yates	I, James L. Yates, attest I am a duly elected or appointed board member, and that I have personally reviewed and approve this application for exemption from audit. Signed <u><i>James L. Yates</i></u> Date: <u>3/20/18</u> My term Expires: May 2020
Board Member 3	Print Board Member's Name Harold R. Smethills	I, Harold R. Smethills, attest I am a duly elected or appointed board member, and that I have personally reviewed and approve this application for exemption from audit. Signed <u><i>Harold R. Smethills</i></u> Date: <u>3/20/18</u> My term Expires: May 2020
Board Member 4	Print Board Member's Name	I _____, attest I am a duly elected or appointed board member, and that I have personally reviewed and approve this application for exemption from audit. Signed _____ Date: _____ My term Expires: _____
Board Member 5	Print Board Member's Name	I _____, attest I am a duly elected or appointed board member, and that I have personally reviewed and approve this application for exemption from audit. Signed _____ Date: _____ My term Expires: _____
Board Member 6	Print Board Member's Name	I _____, attest I am a duly elected or appointed board member, and that I have personally reviewed and approve this application for exemption from audit. Signed _____ Date: _____ My term Expires: _____
Board Member 7	Print Board Member's Name	I _____, attest I am a duly elected or appointed board member, and that I have personally reviewed and approve this application for exemption from audit. Signed _____ Date: _____ My term Expires: _____



CliftonLarsonAllen

CliftonLarsonAllen LLP
www.CLACONnect.com

Accountant's Compilation Report

Board of Directors
Sterling Ranch Colorado Metropolitan District No. 5
Douglas County, Colorado

Management is responsible for the accompanying Application for Exemption from Audit of Sterling Ranch Colorado Metropolitan District No. 5 as of and for the year ended December 31, 2017, included in the accompanying prescribed form. We have performed a compilation engagement in accordance with Statements on Standards for Accounting and Review Services promulgated by the Accounting and Review Services Committee of the American Institute of Certified Public Accountants. We did not audit or review the financial statements included in the accompanying prescribed form nor were we required to perform any procedures to verify the accuracy or completeness of the information provided by management. Accordingly, we do not express an opinion, a conclusion, nor provide any form of assurance on the financial statements included in the accompanying prescribed form.

The Application for Exemption from Audit is presented in accordance with the requirements of the Colorado Office of the State Auditor, which differ from accounting principles generally accepted in the United States of America.

This report is intended solely for the information and use of the Colorado Office of the State Auditor and is not intended to be and should not be used by anyone other than this specified party.

We are not independent with respect to Sterling Ranch Colorado Metropolitan District No. 5.

CliftonLarsonAllen LLP

Greenwood Village, Colorado
February 15, 2018

EXHIBIT C
Amendment to Rules and Regulations

RESOLUTION NO. 2017-11-01

**RESOLUTION OF THE BOARD OF DIRECTORS OF
THE STERLING RANCH COMMUNITY AUTHORITY BOARD
AMENDING ITS RULES AND REGULATIONS COMPILATION
TO UPDATE AND CONFORM THE PROVISIONS, FEES, POLICIES AND
PROCEDURES SET FORTH IN THESE DOCUMENTS**

WHEREAS, the Sterling Ranch Community Authority Board (the “**CAB**”) is an authority and separate legal entity created pursuant to Section 29-1-203, C.R.S. and in conformity with Section 29-1-203.5, C.R.S. and that certain Sterling Ranch Community Authority Board Establishment Agreement, made and entered into effective January 6, 2014 (the “**CABEA**”), by and between the Sterling Ranch Colorado Metropolitan District Nos. 1-7 (collectively, the “**Sterling Ranch Districts**”); and

WHEREAS, the CAB has adopted and amended, from time to time, its Facilities Fees Resolution, Utilities, Parks and Open Space Rules and Regulations, its Rules and Regulations Regarding Covenant Enforcement and Design Review and its Amended Sterling Ranch Water Demand Management Initiatives (the “**Rules and Regulations Compilation**”); and

WHEREAS, the CAB desires to update and conform the provisions of the various documents which comprise its Rules and Regulations Compilation; and

WHEREAS, pursuant to the authority contained in Title 32, Article I, Part 10, C.R.S. and Section 29-1-203, C.R.S., the CAB has the authority to amend the Rules and Regulations Compilation from time to time; and

WHEREAS, the CAB has determined, accordingly, that it is necessary and in the best interest of the health and welfare of the residents of Sterling Ranch to conform and update the Rules and Regulations Compilation, as more particularly described herein;

NOW, THEREFORE, BE IT RESOLVED BY THE BOARD OF DIRECTORS OF THE STERLING RANCH COMMUNITY AUTHORITY BOARD OF THE COUNTY OF DOUGLAS, COLORADO:

Section 1. Replacement of Rules and Regulations Compilation Documents:
Effective January 1, 2018, all versions of the Resolutions Establishing Facilities Fees, Utilities, Parks and Open Space Rules and Regulations, including Exhibit A thereto, the Rules and Regulations Regarding Covenant Enforcement and Design Review and the Amended Sterling Ranch Water Demand Management Initiative shall be deleted entirely and replaced with the following:

A. The Utilities, Parks and Open Space Rules and Regulations dated as being Adopted on November 21, 2017.

B. The Sterling Ranch Community Authority Board Rules and Regulations (Covenant Enforcement/Design Review) dated as being Adopted on November 21, 2017.

C. The Amended Sterling Ranch Water Demand Management Initiatives dated as being Adopted on November 21, 2017.

D. The Rules and Regulations Compilation shall include the Sterling Ranch Residential Property Owners Guidebook dated as being Adopted on November 21, 2017.

E. The Rules and Regulations Compilation shall include the Sterling Ranch Book of Fees and Forms dated as Being Adopted on November 21, 2017.

F. The Rules and Regulations Compilation shall include the Sterling Ranch Community Authority Board Standards and Specifications for Potable Water, Sanitary Sewer, and Non-Potable Water dated November 21, 2017.

Section 2. Defined Terms. Capitalized terms used herein and not otherwise defined herein shall have the meanings given to them in the Rules and Regulations Compilation, unless otherwise indicated herein.

Section 3. Copies. Copies of the Rules and Regulations Compilation, or any part thereof, may be obtained from the CAB Manager at the following address: Sterling Ranch Community Authority Board, c/o Clifton Larson Allen, LLP, 8390 E. Crescent Parkway, Suite 500, Greenwood Village, Colorado 80111, Attn: CAB Manager.

Section 4. Severability. Judicial invalidation of any of the provisions of this Resolution or of any paragraph, sentence, clause, phrase or word herein, or the application thereof in any given circumstance, shall not affect the validity of the remainder of this Resolution, unless such invalidation would act to destroy the intent or essence of this Resolution.

Section 5. Ratification. All provisions of the Rules and Regulations not expressly modified by this Resolution shall remain unchanged and in full force and effect. In the event of any express conflict or inconsistency between the terms of the Rules and Regulations and this Resolution, this Resolution shall control and govern.

[SIGNATURE PAGE FOLLOWS]

**SIGNATURE PAGE TO RESOLUTION OF THE BOARD OF DIRECTORS OF
STERLING RANCH COMMUNITY AUTHORITY BOARD AMENDING ITS RULES
AND REGULATIONS COMPILATION**

ADOPTED AND APPROVED this 21st day of November, 2017.

**STERLING RANCH COMMUNITY
AUTHORITY BOARD**

By:



President

Attest:

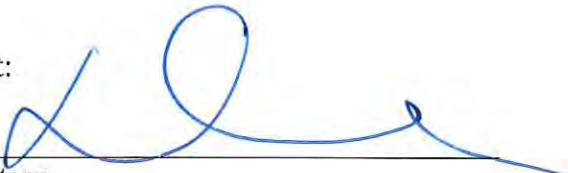

Secretary

**STERLING RANCH COMMUNITY AUTHORITY
BOARD
BOOK OF FEES AND FORMS**

ADOPTED AND AMENDED November 21, 2017

**STERLING RANCH COMMUNITY AUTHORITY BOARD
8390 EAST CRESCENT PARKWAY, SUITE 500
GREENWOOD VILLAGE, COLORADO 80111**

INDEX

1. Fees
 - (a) Covenant Enforcement and Design Review Fees and Charges
 - (b) Monthly Maintenance Fee for Elements at Providence Village
 - (c) Utility Rates, Charges and Restrictions/Water Conservation Measures
2. Resident Forms
 - (a) Violation Complaint – Witness Statement
 - (b) Notice of Alleged Violation
 - (c) Request for a Hearing Before the Enforcement Committee on Notice of Alleged Violation
 - (d) Notice of Violation – Enforcement Committee Determination
 - (e) Request for a Hearing Before the CAB Board on Enforcement Committee Notice of Violation
 - (f) Notice of Determination of CAB Board on Appeal from Enforcement Committee Notice of Violation
 - (g) Request for a Hearing Before the CAB Board Appealing Design Review Committee Denial of a Variance
3. Builder Forms
 - (a) Water and Sewer Connection Instructions
 - (b) Permit to Connect to Water and Sewer Services in Filing No. 1
 - (c) Landscape Inspections and Instructions
 - (d) Policies, Procedures, Fees and Forms for the Colorado Parks and Wildlife Parks Pass Program
 - (e) Policies, Procedures, Fees and Forms for the Use of Sterling Ranch Information Center

COVENANT ENFORCEMENT AND DESIGN REVIEW FEES AND CHARGES

COVENANT ENFORCEMENT AND DESIGN REVIEW

Fees and Charges

I. COVENANT ENFORCEMENT & DESIGN REVIEW FEES AND CHARGES

A. Covenant Enforcement Charges

First Notice of Violation of the Documents	\$100.00
Second Notice of Violation of the Documents	\$250.00
Third Notice Violation of the Documents	\$500.00
Continuing Violation	*Cost to Correct Violation

*Based upon Continuing Violation of the Documents, the Cost for the CAB to Correct the Violation will be billed to the owner of the Lot in Violation of the Documents.

B. Design Review Services, Landscape Review, Improvement Review

DRC Design Review Fee per new Floor Plan	\$2,500.00
DRC Landscaping Plan Review Fee	\$300.00
DRC Lot Review Fee for Approved Floor Plan	\$150.00
DRC Improvement Inspection Fee	\$100.00
DRC Landscape Inspection Fee	\$100.00
DRC Voluntary Water Audit Fee	\$250.00

C. Landscape Professional Registration Fees

Design Professional Certification	\$350.00
Installation Professional Certification	\$350.00

II. Utility Information

Predictive Analytics for Energy Consumption	\$12.00 per month
---	-------------------

A. Voluntary Energy Usage, Predictive Analytics, and Predictive Billing Services Fees

Customers who agree to share their energy usage information with the CAB will be given predictive analytics on their energy usage patterns relative to the

community, predictions about anticipated monthly usage, and anticipated monthly energy bills.

B. Manually Reading Indoor and Outdoor Water Meters

Customers who do not have an internet connection to the home, or chose not to have the CAB's Water Meters, or chose not to connect their water meter to the internet will be subject to a monthly charge in order for a technician to manually read the meters.

Fee for Manual Water Meter Reading \$25.00 per month

C. Residential Trash Collection, Recycling and Disposal Charge

The CAB provides its residents with non-hazardous municipal solid waste residential trash collection, recycling and disposal services. The Trash Collection, Recycling and Disposal Charge is a fixed charge that accompanies the water and sanitary charges on a monthly basis. The monthly charge for this service is \$12.40 per unit. All residential customers will pay the charge.

D. Fencing Materials

The Covenants, Conditions and Restrictions (the “CC&R’s”) and the Design Review Guidelines for the CAB specify the fencing material to be used in the Sterling Ranch project. Fencing material meeting these guidelines is sold by the CAB. The unit prices for the materials are listed below.

**FENCING MATERIAL CHARGES
EFFECTIVE AS OF JANUARY 1, 2018**

Description of Product	Unit of Measure	Unit Price
8' Rail, Sandstone Colored Concrete	ea	\$34.25
In-line Post / end Post, Sandstone Colored Concrete	ea	\$44.15
In-line Post Cap, Sandstone Colored Concrete	ea	\$5.45
Corner Post, Sandstone Colored Concrete	ea	\$68.40
Corner Post Cap, Sandstone Colored Concrete	ea	\$5.45
10' Tall End Post, Sandstone Colored Concrete	ea	\$86.95

Delivery, freight and installation costs are not included. All purchases are subject to the applicable sales and use tax for the jurisdiction.

MONTHLY MAINTENANCE FEE FOR ELEMENTS AT PROVIDENCE VILLAGE

MONTHLY MAINTENANCE FEE FOR ELEMENTS AT PROVIDENCE VILLAGE

Residences within the Elements at Providence Village are subject to the Supplemental Declaration of Covenants and Conditions and Restrictions for Elements at Providence Village (the “Elements at Providence Village Sup Dec”).

To provide the maintenance services required of the CAB by the Elements at Providence Village Sup Dec the CAB has established a monthly fee of \$14.50 per lot per month to be payable for a particular lot on or about the first day of each month following the date on which a certificate of occupancy has been issued for a residential unit on the lot. Like all other fees established by the CAB, the CAB has the authority to adjust these fees from time to time.

UTILITY RATES, CHARGES AND RESTRICTIONS/WATER CONSERVATION MEASURES

Utility Rates, Charges and Restrictions
Effective as of January 1, 2018

I. DEFINITIONS

The following definitions apply to this section on Rates and Charges. Except as may be otherwise noted, all capitalized terms shall have the meanings defined in the Regulations – Utilities, Parks and Open Space of the Sterling Ranch Community Authority Board, as may be amended.

- A. Applicant:** The person or entity that files an Application.
- B. Application:** An application form, as designated by the Utility Director of the CAB to provide the necessary information for evaluating water or sanitary sewer service. The party filing the Application shall be the Applicant.
- C. CAB and Dominion:** All property and facilities owned by the CAB and Dominion, shall be exempt from the payment of any and all Tap Fees described herein for property and facilities in Filing 1. For any property and facilities owned by CAB and Dominion in any Filing other than Filing 1, Tap Fees and all rates and charges described herein shall apply.
- D. Customer:** Shall mean any person, firm, corporation, association or agency who is authorized, or who desires to obtain services from the CAB and is a connector to or user of the CAB Facilities.
- E. General Manager:** Shall mean the Person designated as General Manager by the CAB Board, who administers and supervises the affairs of and operations and maintenance of the facilities of the CAB or the Person authorized by the CAB Board or the General Manager to act on his or her behalf.
- F. Hydrant Permit:** A permit issued by the CAB for temporary construction water.
- G. Multi-family Residential Dwelling Unit Service:** A residential dwelling unit as defined below located in a single structure containing three or more residential dwelling units on a single lot.
- H. Non-Potable Irrigation Service:** Service provided to any user who has been approved to use non-potable water for irrigation purposes by the CAB. The rate may be a result of either contracting for use of non-potable (untreated) or reuse water.
- I. Nonresidential Service:** Service to any nonresidential use, including, but not limited to, the following: retail, office, hotel, motel, restaurant, service facility, manufacturing, warehouse, recreation uses and various institutional uses such as museums, convention centers, hospitals, schools, places of worship, etc. A separate meter is required for each nonresidential structure requiring service. In order to be considered a single structure, the structure must have; a common foundation; a common wall; a common roof; and common ownership. If any of the above is missing the structure will be classified as multiple structures and require payment of Tap Fees for each structure.

- J. Owner:** Shall mean any Person, firm, corporation, association or agency who holds title to any real property or building served by the CAB.
- K. Residential Dwelling Unit Service:** A residential dwelling unit is a structure or part of a structure containing one or more rooms and a single kitchen arranged, designed and intended as a unit for occupancy by one family living independently of others, including panelized, prefabricated, modular or other factory-produced buildings and mobile homes; but excluding therefrom hotels and motels.
- L. Sports Field Service:** A sports field is defined as an area of turfgrass used and managed for organized sporting activities. The CAB recognizes that sports fields experience significant usage outside of our normal irrigation season of April 15 to October 15. These activities can require supplemental irrigation water in order to keep fields in good condition and safe. Classification as a Sports Field Customer will provide the customer with an annual irrigation budget rather than a defined budget for each monthly billing cycle.
- M. Sterling Ranch Districts.** Sterling Ranch Metropolitan District Nos. 1-7
- N. Water Budget:** Budget established for water use by each customer service type as shown in Exhibit A-1.
- O. Water Irrigation Service:** Service for water irrigation available only for the common landscaped area of any Multi-Family Residential use or Nonresidential use.

II. TAP FEES

- A.** Tap Fees to be paid for Residential Lots in Filing 1 shall be paid as follows: any Applicant, Owner or Customer desiring Retail Water Service and Retail Wastewater Service from the CAB for Lots in Filing 1 shall pay to the CAB the Tap Fees as set forth in Appendix I attached hereto.
- B.** Tap Fees to be paid for all Lots and Non-Residential Parcels, other than those Residential Lots in Filing 1, on or after January 1, 2018 shall be paid as follows: any Applicant, Owner or Customer desiring Retail Water Service and Retail Wastewater Service from the CAB shall pay to the CAB the Tap Fees as set forth below. The Tap Fees shall include the Stormwater Tap Fees. Such Tap Fees shall be paid in addition to all other charges relating to water or sanitary sewer service described elsewhere in this section on Rates and Charges.

TAP FEES
EFFECTIVE AS OF JANUARY 1, 2018

Description	CAB Tap Fees (for Retail Service)	Dominion Tap Fees (for Wholesale Service)	Total Tap Fees
Water Tap			
Residential			
Single Family Detached and Attached (Per Unit) - 3/4" Tap	\$1,600	\$26,000	\$27,600
Single Family Attached and Multifamily (Per Unit) - 5/8" Tap	\$1,200	\$19,500	\$20,700
Pool Tap	N/A	\$13,000	\$13,000
Non-Residential			
Indoor Water Tap (per EQR)	\$1,600	\$26,000	\$27,600
Non-Residential and Irrigation			
5/8"	\$1,200	\$19,500	\$20,700
3/4"	\$1,600	\$26,000	\$27,600
1"	\$2,670	\$43,420	\$46,090
1 1/2"	\$5,330	\$86,580	\$91,910
2"	\$10,670	\$173,420	\$184,090
3"	\$26,670	\$433,420	\$460,090
Sewer Tap			
Residential			
Single Family Detached and Attached (Per Unit) - 3/4" Tap	\$700	\$7,800	\$8,500
Single Family Attached and Multifamily (Per Unit) - 5/8" Tap	\$525	\$5,850	\$6,375
Non-Residential			
5/8"	\$525	\$5,850	\$6,375
3/4"	\$700	\$7,800	\$8,500
1"	\$1,170	\$13,030	\$14,200
1 1/2"	\$2,330	\$25,970	\$28,300
2"	\$4,670	\$52,030	\$56,700
3"	\$11,670	\$130,030	\$141,700
Stormwater Tap			
Residential			
Per Unit	\$4,600	N/A	\$4,600
Non-Residential			
Non-Residential	**	N/A	**

** Calculated on a case-by-case basis dependent on impervious area

Note: Any Applicant, Owner or Customer who is a party to a contract for the purchase of Taps with the CAB, and who is not in default under the contract, shall pay Tap Fees at the rate and at the times set forth in such contract.

****Applicants, Owners and Customers are hereby notified that additional capital fees shall be due and owing for each Unit in Sterling Ranch in addition to the Tap Fees described above; the Tap Fees DO NOT equal the cumulative fees payable for each Sterling Ranch Unit.**

Please contact the CAB to obtain a current, comprehensive list of capital fees payable for each Unit type in Sterling Ranch.

C. Tap Fee Payments and Applications

1. The Tap Fees for Residential Dwelling Units or structures containing Multi-Family Residential Dwelling Units shall be paid prior to receipt of a building permit; provided, however, that notwithstanding the foregoing, Tap Fees for Residential Dwelling Units for Sterling Ranch Filing 1 according to the Final Plat thereof recorded on November 6, 2015, as Reception No. 2015080636 in the office of the Douglas County Clerk and Recorder and the Sterling Ranch Filing 1, 1st Amendment, recorded on November 6, 2015, as Reception No. 2015080659, shall be paid in accordance with the Tap and Facilities Fee Purchase Agreements executed by and among the CAB, First American Title Insurance Company, CliftonLarsenAllen LLP and each of the Filing 1 master builders on November 5, 2015 (collectively, the “**TFFPAs**”).
2. The Tap Fees for Nonresidential Service Water Irrigation Service and Open Space Irrigation Service shall be paid at the time of submittal of the Application for Water and Sewage Service, in accordance with the meter size as approved by the CAB.

The Applicant shall have filed this Application for Water and Sewage Service; obtained the CAB's approval thereof; and have executed an Industrial Pretreatment Plant or Industrial Sewer Agreement, if applicable prior to the application for a building permit.
3. Payment of Tap Fees may be made in advance of the above time limits as long as the following conditions are met:
 - a. For residential development a building permit from Douglas County has been obtained.
 - b. For Non Residential development Douglas County has approved a Site Plan.
 - c. The uses for which Tap Fees are being paid are to be located within an area that the CAB is contractually obligated to serve.
 - d. The number of Residential Dwelling Units, Multi-Family Dwelling Units, or Nonresidential taps for which Tap Fees are being paid does not exceed the number allowed for the property upon which they are to be located.
4. After payment of the Tap Fee, the Applicant or owner has 365 days to complete the connection to the property. Said connection will be

considered complete upon approval of the CAB of the installation of the required meter(s). Unless the CAB has approved in writing otherwise, the failure to complete the connection within such 365-day period requires the Applicant, Owner, or Customer to pay the incremental cost, if any, necessary to adjust the amount paid to equal the Tap Fee current at the time of connection in order to complete the connection.

5. Pursuant to Section 32-1-1001(1)(j), C.R.S., the Tap Fees shall, until paid, constitute a perpetual lien on and against the property subjected to the Tap Fees hereunder from and after the date of adoption by the Board of Directors of the CAB, which lien may, if not paid when due, be foreclosed upon in the same manner as provided by the Laws of the State of Colorado for the foreclosure of mechanics' liens. Notwithstanding the payment schedules established in the TFFPAs, for purposes of the CAB's foreclosure on its perpetual lien, the Filing 1 Tap Fees shall become due to the CAB upon Substantial Completion of the Finished Lot Improvements and Trunk Improvements for each Construction Phase of Filing 1, as more particularly described in the TFFPAs. Except for the lien against the property within the Sterling Ranch Districts created by the imposition of property taxes by the Sterling Ranch Districts and other taxing jurisdictions pursuant to Section 32-1-1202, C.R.S., all liens for unpaid Tap Fees shall, to the fullest extent permitted by law, have priority over all other liens of record affecting the property subject to such Tap Fees and shall run with such property and remain in effect until paid in full. In the event a partial payment of the total amount due for the Tap Fees and Facilities Fees for a residential unit is received by the CAB, the partial payment shall first be applied to payment of the Dominion Tap Fees, then to the CAB Facilities Fee, then to the CAB Stormwater Tap Fee, then to the CAB Water Tap Fee, then to the CAB Sanitary Sewer Tap Fee due for such residential unit.

D. Temporary Service Connection Permit Charge

1. A charge of \$500 per year per equivalent shall be paid for temporary water service or temporary sanitary sewer service. A temporary service connection cannot exceed five years. Any Temporary Service Connection Permit Charges paid will not be applied against the cost of the Tap Fee for permanent service.
2. An initial deposit of \$2,000 will be required to cover the cost of removal of the temporary connection if permanent service is not initiated within five years.

- E.** The purpose of these Tap Fees is to allocate the cost of facilities equitably among the users of the facilities. The General Manager shall interpret the provisions of this document in order to establish such equity at his discretion.

III. CONSTRUCTION PERIOD FEES and PENALTIES

A. Water Meter, Construction Water and Inspection Fees and Penalties

The charge for providing and installing a meter, miscellaneous water usage during the construction period and inspection of the improvements shall be based on the size of the water meter in accordance with the following schedule:

Meter Size	Meter Type	Meter Fee		Construction Water Fee (a)	Inspection Fee (e)
		Cost	Install		
3/4"	Siemens Dual Water	\$2,340	\$35	\$ 50	\$150
3/4"	Siemens Single Water	\$1,800	\$35	\$ 50	\$100
1"	Disc (Res.)	(b)	\$35	\$ 78	\$700
1 1/2"	Disc (Res.)	(b)	\$35	\$ 140	\$800
2"	Disc (Res.)	(b)	\$35	\$ 265	\$900
2"	Turbine	(b)	\$35	\$ 265	\$900
2"	Compound	(b)	\$35	\$ 265	\$900
3"	Turbine	(b)	\$35	\$ 577	\$900
3"	Compound	(b)	\$35	\$ 577	\$900

Notes:

- a) One-time fee per meter for water used during construction period. This fee does not include water for landscaping installed prior to installation of a meter. Any landscaping installed prior to installation of a water meter shall be assessed a **\$250** fee plus a billing for water consumption based upon an estimate of water consumed.
- b) The CAB shall charge the actual cost of the meter purchased based on the LIFO method of accounting.
- c) All meters shall be installed at the Applicant, Owner or Customer's expense.
- d) Meter size shall be as reviewed and approved by the CAB. Meter sizing shall be based on the specifications outlined in Manual M22 "Sizing Water Service Lines and Meters" as published by the American Water Works Association as may be modified from time to time by administrative directive of the General Manager. The water service line between the main and the meter shall be the same size as the meter, unless otherwise approved by the CAB Engineering Department.
- e) The inspection fee is allocated between water and sanitary sewer service. Said fee covers the inspector's time for insuring that the water and sewer laterals are constructed per specifications as well as associated administrative costs of establishing the new account.
- f) For each additional inspection required due to failure of the Applicant, Owner or Customer to have facilities ready for the requested inspection, or if the facility has not been brought within specifications as noted on earlier inspections, an additional re-inspection fee of **\$125** will be charged.

- g) All meters shall be installed prior to receipt of a Certificate of Occupancy from the Douglas County Building Department. The fine for failing to install a meter prior to receiving the Required Certificate of Occupancy shall be **\$1,000**.
- h) A backflow prevention inspection shall occur at the time of installation of the irrigation system and a backflow prevention inspection fee in the amount of \$150 shall be paid by the Applicant at the time of submittal of the Application for such imposition.

B. Hydrant Meter Fees

1. Permit Fees

Temporary construction water may be provided by the CAB by application for and approval of a Hydrant Permit as approved by the General Manager of the CAB, in accordance with the terms thereof. The permit will be accompanied by a deposit determined by the CAB which will be at least 25% greater than the replacement cost of the hydrant meter(s) subject to the Hydrant Permit and will be returned net of any damages to the meter or unpaid charges for hydrant water consumed.

2. Usage Fees

The minimum monthly charge shall be \$50. All usage shall be billed at the non-residential irrigation usage rate for 100% to 120% of budget. A \$25 late/non-reporting fee shall be assessed on any account not reporting their meter reading as required by the Hydrant Permit.

C. Plan Review Fees

All residential and non-residential properties will require a utility plan review fee based on the established categories. The fee is due upon submittal of plans for review.

Category	Flat Fee	Incremental
Residential Single Family Water Plan Review (per	\$100	\$2 per linear
Residential Multifamily Water Plan Review (per	\$75	foot of water
Basic Non-residential Remodel	\$150	and sewer
Remodel Requiring Revised Plumbing	\$300	laterals from
Remodel Requiring External Improvements	\$500	water main
		to water

IV. USER RATES AND CHARGES

The CAB bills for all customer usage classifications on a monthly basis. The fees are as follows:

A. Water Service Availability Fee

**WATER SERVICE AVAILABILITY CHARGE
EFFECTIVE AS OF JANUARY 1, 2018**

Description / Tap Size	Monthly
------------------------	---------

	Fee
Residential	
Single Family Detached and Attached (Per Unit) - 3/4" Tap	\$58.00
Single Family Attached and Multifamily (Per Unit) - 5/8" Tap	\$43.50
Non-Residential and Irrigation	
3/4"	\$58.00
1"	\$68.50
1 1/2"	\$74.00
2"	\$114.00
3"	\$256.00

B. Indoor Water Consumption Fee

The rate structure assumes an individualized water budget, adjusted annually beginning with the calculation of the March consumption to be invoiced in April, using the average winter consumption (AWC). The AWC is the Customer's actual water use for the months of December, January, and February and is based on a Customer's individual water consumption characteristics. Accounts without an AWC history will be assigned 8,000 gallons per month as an initial AWC. Upon transfer of property to a new Owner the Account for that property will be established as a new account with no AWC history.

	Tier	Fee per 1,000 gallons (2017)	Fee per 1,000 gallons (2018)
Tier 1	<100% of AWC	\$6.65	\$6.90
Tier 2	100% to 120% AWC	\$8.20	\$8.50
Tier 3	>120% of AWC	\$12.25	\$12.70

C. Outdoor Water Consumption Fee

	Tier	Fee per 1,000 gallons (2017)	Fee per 1,000 gallons (2018)
Tier 1	Annual Water Allotment <100%	\$8.20	\$8.50
Tier 2	Annual Water Allotment 100% - 120%	\$12.25	\$12.70
Tier 3	Annual Water Allotment 120% - 140%	\$16.35	\$16.95
Tier 4	Annual Water Allotment >140%	\$20.00	\$20.70
Tier 5	Construction Water	\$11.75	\$12.25

D. Sanitary Sewer Fee

Sanitary sewer fees are comprised of two components – a yearly base fixed fee plus a volumetric usage fee. The usage fee is calculated using indoor water use only. All customers will pay the base fixed fee.

Customer Class	Base Fixed Fee (2017)	Base Fixed Fee (2018)	Fee per 1,000 gallons of Indoor Water Use (2017)	Fee per 1,000 gallons of Indoor Water Use (2018)
Residential				
Single Family	\$31.00	\$32.00	\$6.65	\$6.85
Multi Family	\$31.00	\$32.00	\$6.65	\$6.85
Non-Residential				\$7.40
	\$52.00		\$7.15	
¾"		\$32.00		\$7.40
1"		\$38.00		\$7.40
1 ½"		\$42.00		\$7.40
2"		\$63.00		\$7.40
3"		\$142.00		\$7.40

E. Stormwater Fee

The stormwater fee is a fixed monthly fee that accompanies the water and sanitary sewer fees and shall apply to a Lot upon issuance of a certificate of occupancy from Douglas County. All Customers will pay the monthly stormwater fee invoiced on the first day of the month following the month for which the fee is assessed, and the fee shall be due within thirty (30) days of invoice. The first billing to a Lot upon issuance of a certificate of occupancy shall be for the month in which the certificate of occupancy was issued.

**STORMWATER CHARGE
EFFECTIVE AS OF JANUARY 1, 2018**

Customer Class	Monthly Charge
Residential	
Single Family	\$14.00
Multifamily	\$13.00
Non-Residential	
Non-Residential	**

* The monthly Nonresidential stormwater charge will be determined based upon the stormwater tap fee calculated, converting the tap fee into the number of single family stormwater tap equivalents (EQRs) and then multiplying the number of EQRs by the monthly single family charge

The CAB bills for all customer usage classifications on a monthly basis. The fees are as follows:

F. Street Lighting Fee

The Street Lighting fee is a fixed fee that accompanies the water and sanitary fees on a monthly basis. All customers will pay a street lighting fee.

**STREET LIGHTING CHARGE
EFFECTIVE AS OF JANUARY 1, 2018**

Customer Class	Minimum Monthly Charge
Residential	
Single Family (Per Residence)	\$7.00
Multifamily (Per Residence)	\$7.00
Non-Residential (Up to 12,000 SF of Rentable Space) **	\$21.00

** For each 3,000 SF of rentable space in excess of 12,000 SF, the minimum monthly charge will increase by \$7.00 per month

G. Service Outside CAB

For service pursuant to any or all of the foregoing paragraphs A through D outside of the boundaries of the Sterling Ranch Colorado Metropolitan District Nos. 1-7, such fees and Rates shall equal one and a half times the amount set forth in such paragraphs A through D; provided, however that Customers receiving service in accordance with the Chatfield Valley Water Supply Framework shall pay rates in accordance with the applicable Water Supply Agreement approved by Dominion Water and Sanitation District.

H. Backflow Prevention Device Penalty

A backflow inspection fee of \$150.00 shall be due prior to inspection. A penalty of \$15 per month (billed monthly) will be imposed and assessed for all CAB customers who have not installed a proper backflow prevention device.

I. Delinquent Payment Penalty

Pursuant to Section 8.5 of the Rules and Regulations, a penalty of \$10 will be assessed on all past due accounts.

J. Shutoff Posting Fee

A fee of \$20 will be assessed upon posting of notice of shut off.

K. Interest Fee

Interest at a rate of 12% per annum shall be assessed on the past due balance of accounts that have had service suspended.

L. Failure to Provide Access Penalty

A penalty based on the schedule below will be assessed for all customers who fail to provide access pursuant to Section 4.4 of the Rules and Regulations after proper notice has been provided.

	First Billing Period	Second Billing Period	All Subsequent Billing Periods
Penalty	\$50	\$100	\$250

M. Initial and Final Billing Fees

Requests for change in service that requires a meter reading and/or bill outside the normal billing cycle will be assessed a \$25 fee.

N. Disconnection and Reinstatement Charge

Charges for disconnection and reinstatement of service attributable to delinquent accounts will be assessed as follows: Charges for all services will be billed through the shut off date, and then resume when water is reinstated.

Actual disconnection and reinstatement \$125

O. Returned Check Fee

A fee shall be assessed for any dishonored checks as follows:

First Occurrence	Double the cost charged by bank
Second Occurrence	Triple the cost charged by bank
Third Occurrence	Notice pursuant to CRS 13-21-109(2) will be given and the CAB shall collect the amount due thereunder

P. Bankruptcy

Upon receipt of written notification of bankruptcy, a final meter reading for the account will be ordered. The account will be final billed and a new account number established. Notation will be made on both accounts as to the details of the bankruptcy.

To continue service to the new account receipt of a deposit, equal to three times the average monthly bill rounded to the next highest \$5 increment, must be received within 10 working days of the mailing of notice. Notification of the required deposit will be made to the address by first class mail. Failure to make the required deposit will result in the shut off of service.

Until paid all such charges shall remain a perpetual lien on and against the property as are all of the fees and charges due to the CAB.

Q. Meter Testing Deposit

A deposit of \$25 shall accompany all written requests by Customers to have their water meter tested.

R. Wastewater Treatment Surcharge

A surcharge may be charged to Customers that discharge wastewater with higher oxygen demand or solids loadings than those found in typical domestic wastewater. These charges will cover the additional costs incurred to treat the wastewater. The surcharge is calculated using a formula specified below.

$$SC = V (8.34) [(AOD) \times (UCo) + (TSS-300) \times (UCs)]$$

SC = surcharge in dollars and cents

V = volume of wastewater discharged in units of million gallons

8.34 = conversion factor (gallons to pounds)

AOD = additional oxygen demand in units of milligrams per liter

Note: for use in the formula above, first determine if BOD (Biochemical Oxygen Demand) or COD (Chemical Oxygen Demand) should be used in the determination of AOD by using the following determination:

- 1) If the ratio of COD to BOD (as mg/l) is less than 3.0 then AOD = (BOD – 250) (Typical domestic wastewater contains less than 250 mg/l BOD)
- 2) If the ratio of COD to BOD (as mg/l) is greater than or equal to 3.0 then AOD = (COD – 500). (Typical domestic wastewater contains less than 500 mg/l COD).

UCo = cost of treating a pound of additional oxygen demand (AOD). The cost is \$0.07 per pound of AOD.

TSS = total suspended solids in units of milligrams per liter. (Typical domestic wastewater contains less than 300 mg/l TSS).

UCs = cost of treating a pound of total suspended solids (TSS) in dollars and cents. The cost is \$0.03 per pound of TSS.

S. Charges for violation of Mandatory Outdoor Water Use Restrictions:

Compliance with the Mandatory Outdoor Water Use Restrictions (see Exhibit A-2) will be determined by CAB and the following charges for violations thereof shall apply:

- The first annual offense will result in a recorded violation documented by a letter.
- The second offense would result in a recorded violation documented by a letter and assessing a fee to the customer's bill water bill.
- All following offenses would result in a recorded violation documented by certified letter and assessing a fee to the customer's water bill as stated in the table below.

All violations would allow for a 10 day grace period prior to the next violation being recorded allowing for mail delivery and system corrections. Failure to pay charges will result in suspension of water service.

**CHARGES FOR VIOLATION OF MANDATORY OUTDOOR WATER USE RESTRICTIONS
EFFECTIVE AS OF JANUARY 1, 2018**

Service Type / Meter Size	Violation					
	1st	2nd	3rd	4th	5th	Subsequent
Residential	Warning	\$50	\$100	\$250	\$500	Water Shut Off
1" Tap or Less	Warning	\$100	\$200	\$500	\$1,000	Water Shut Off
1 1/2" Tap or Greater	Warning	\$600	\$1,200	\$3,000	\$6,000	Water Shut Off

Water Budget Definition and Calculation

I. Water Budget Calculation:

For each tap a Water Budget will be established by CAB that will serve as the benchmark for where different rate tiers take effect. The Water Budget for different types of Customers shall be determined as follows:

A. Non-Residential Indoor Customers

Indoor Usage: Allowance for water budget is based on 189 kgal per ¾” equivalent as tabulated below:

<u>Meter Size</u>	<u>Annual Water Budget</u>
¾"	189,000
1"	378,000
1.5"	756,000
2"	1,512,000
3"	3,402,000

B. Non-Residential Irrigation Customers

For non-residential irrigation Customers the outdoor irrigation budget will be calculated based on the actual number of irrigated square feet (irrigated area) including turf and landscape beds.

The Customer is responsible for fully completing the Non-Residential Irrigators Water Budget Application.

1. The Customer may utilize agents, contractors or management companies to complete the Application however the Customer assumes responsibility for the application.
2. It is the responsibility of the Customer to inform the CAB if any changes are made which change the irrigated area.
3. If the Customer does not submit the completed Non-Residential Irrigators Water Budget Application the Water Budget will be based on **15%** of the total lot size.
4. If a Customer believes that the measurement used to calculate their budget is incorrect the following administrative steps will be taken:
 - The Customer must report to the CAB the corrected measurement to be used as a basis for calculating the water budget in writing.
 - The CAB will verify the information provided.
 - A refund will be provided but is limited to the irrigation periods 2 years prior to when notice was given to the CAB.

Non-residential Irrigation Customers will fall into the following categories:

- Outdoor Irrigation Usage for Multi- Family common areas and Associations

Outdoor Usage: The amount of water necessary to apply the irrigation amounts shown in Section B below on an area equal to the actual irrigated area of landscape.

- Non-Residential

Outdoor Usage: The amount of water necessary to apply the irrigation amounts on an area equal to the actual irrigated area of landscape.

- Sterling Ranch Community Authority Board

Outdoor Usage: The amount of water necessary to apply the irrigation amounts on an area equal to the actual irrigated area of landscape.

- Sports Field Customers

Outdoor Usage: The amount of water necessary to apply to the actual irrigated area of landscape on an annual basis.

- Customers primarily using non-potable

Outdoor Usage: The amount of water necessary to apply to the actual irrigated area of landscape on an annual basis or as revised by contract.

C. Residential Water Customers/ Indoor Water Usage

1. Indoor Usage: The rate structure assumes an individualized water budget, adjusted annually beginning with the calculation of the March consumption to be invoiced in April, using the average winter consumption (AWC). The AWC is the Customer's actual water use for the months of December, January, and February and is based on a Customer's individual water consumption characteristics. Accounts without an AWC history will be assigned 8,000 gallons per month as an initial AWC. Upon transfer of property to a new Owner the Account for that property will be established as a new account with no AWC history.
2. Outdoor Usage: Allowance for the water budget shall be based upon the Outdoor Water Allotment established by the CAB for the Lot using the process and criteria set forth in the Water Demand Management Initiatives. The calculation of the area to be included in the Outdoor Usage shall include both the Lot and tree lawn from the back of curb to the sidewalk in the street right of way along the perimeter of their Lot.

Water Conservation Measures

I. Water Use:

Consistent with the Water Demand Management Initiatives wasteful use of water is prohibited at all times. Examples of wasteful water use include:

- Excess water flowing in street gutters from irrigation or other outdoor uses,
- Unrepaired leaks or fixture malfunctions that lead to excess water use

II. Mandatory Outdoor Water Restrictions:

Consistent with the Water Demand Management Initiatives concerning Mandatory Outdoor Water Restrictions the following restrictions apply at all times:

- Outdoor irrigation is prohibited between the hours of **10:00 A.M. and 6:00 P.M. from May 1st to September 30th** with exception of prior approved daytime watering permit.
- Operation of an irrigation system for maintenance is allowed at any time. Maintenance is defined as actively observing an irrigation zone while it is operating to ensure that it is functioning properly. A person must be visible at the location of the zone while it is running. Each zone must be turned off prior to leaving the location and not left running until the completion of a cycle.
- Hand watering of landscape materials is allowed at any time. Hand watering is defined as the application of irrigation from a hose held in the hand with a shut off valve; or a water-conserving method such as a drip, trickle, micro spray, deep root watering device or watering can.
- Car washing is allowed at any time. However, if water for car washing is coming from a hose rather than a bucket, a hose end shut off device must be in use to prevent uninterrupted water flow.

III. Changes to Mandatory Outdoor Water Restrictions:

The mandatory Outdoor Water Restrictions imposed by the Rules and Regulations may be changed at any time by declaration of CAB Board of Directors at a regular or special board meeting. Such changes may include, but are not limited to:

- Mandatory day-of- week limits on irrigation
- Mandatory limits on the hours of watering
- Mandatory limits on the allowed run times of irrigation systems
- Mandatory prohibitions of all outdoor water use under severe water supply shortages

IV. Required Water Conservation Devices:

- A. The irrigation system of any Non-Residential Irrigation Customers (Non Residential, industrial, combination, governmental or HOA common area irrigation system) that receives water from the CAB must be equipped with rain sensing shut-off devices approved as to number and type by the CAB.

- B.** All rain sensors shall be installed, adjusted and set as follows:
1. to automatically shut off the irrigation system after 1/4" (one-fourth of an inch) of rainfall has been received and is recommended to be shut off after 1/8" (one-eighth of an inch).
 2. according to manufacturer's instructions in a location that will provide full exposure to rainfall such that accuracy of operation is assured and shall be maintained in good working condition.
- C.** No person shall, with the intent of circumventing the purpose of this requirement, adjust either the rain sensor or irrigation system so that the rain sensor is not able to override and turn off the irrigation system after one-fourth inch of rain has fallen.
- D.** A person commits a violation if, on premises owned, leased or managed by him or her, he or she:
1. Installs, or causes or permits the installation of, an irrigation system in violation of the above.
 2. Operates, or causes or permits the operation of, an irrigation system that does not comply with the above.

Violations will be subject to the warning and fees as shown below except in the case of failure to have a rain sensor device properly installed the fine will be \$250.

Meter type/service	1st	2nd	3rd	4th	5th	Subsequent
1" or less	warning	\$100	\$200	\$500	\$1,000	water shut off
1-1/2" or greater	warning	\$600	\$1,200	\$3,000	\$6,000	water shut off

FACILITIES FEES

Facilities Fee. Facilities Fee are to be paid on all residential property within the Sterling Ranch Districts at or prior to the date of issuance of a building permit, in the amount of \$7,500.00 per residential unit for Facilities Fees paid through December 31, 2017 and \$8,500 per residential unit as of January 1, 2018 and thereafter until further adjustment by the Board. Facilities Fees for residential units in the boundaries of Filing 1, Sterling Ranch Planned Development according to the Final Plat thereof dated November 6, 2015, and recorded as Reception No. 2015080636 in the Office of the Douglas County Clerk and Recorder, and the Sterling Ranch Filing No. 1, First Amendment dated November 6, 2015, and recorded as Reception No. 2015080659 (collectively, “Filing 1”) are due and shall be paid in accordance with the Tap and Facilities Fee Purchase Agreements executed by and among the CAB, First American Title Insurance Company, CliftonLarsenAllen LLP and each of the Filing 1 master builders (the “Builders”) on November 5, 2015 (collectively, the “TFFPAs”). The Facilities Fee shall be paid to the CAB. The CAB may impose penalties for non-compliance as permitted by law. Upon collection of the Facilities Fee by the CAB and provision of an adequate legal description of the subject property, the CAB shall cause a release of its lien, applicable to the subject property. Without limiting the foregoing, a late charge on any past-due amounts shall accrue from the date due at a rate of \$150.00 per month, or up to five percent per month, not to exceed twenty-five percent of the amount due, whichever is greater. Nothing herein shall prevent any party from prepaying the Facilities Fee at any time with the consent of the CAB.

Section 2. **Modification.** The Facilities Fee policy adopted herein and the rate thereof have been established based on projected budgetary requirements of the CAB using various assumptions regarding the cost of public improvements, bond issues and interest rates therefor, together with operations expenses and maintenance expenses. Actual costs may differ from projections, and the CAB may determine to modify the Facilities Fee imposed hereunder from time to time.

Section 4. **Status as Lien/Foreclosure.** Pursuant to Section 32-1-1001(1)(j), C.R.S., the Facilities Fee shall, until paid, constitute a perpetual lien on and against the property subjected to the Facilities Fee hereunder from and after the date of adoption by the Board of Directors of the CAB, which lien may, if not paid when due, be foreclosed upon in the same manner as provided by the Laws of the State of Colorado for the foreclosure of mechanics’ liens. Notwithstanding the payment schedules established in the TFFPAs, for purposes of the CAB’s foreclosure on its perpetual lien, the Filing 1 Facilities Fees shall become due to the CAB upon Substantial Completion of the Finished Lot Improvements and Trunk Improvements for each Construction Phase of Filing 1, as more particularly described in the TFFPAs. Upon payment of the appropriate Facilities Fee and a request by the party making the payment, the properties subject to such Facilities Fee shall be released from the lien thereof by the recording of a form of Release of Lien by the CAB.

Section 5. **Priority of Lien.** Except for the lien against the property within the Sterling Ranch Districts created by the imposition of property taxes by the Sterling Ranch Districts and other taxing jurisdictions pursuant to Section 32-1-1202, C.R.S., all liens for unpaid

Facilities Fees shall, to the fullest extent permitted by law, have priority over all other liens of record affecting the property subject to such Facilities Fees and shall run with such property and remain in effect until paid in full. In the event a partial payment of the total amount due for the Tap Fees and Facilities Fees for a residential unit is received by the CAB, the partial payment shall first be applied to payment of the Dominion Tap Fees, then to the CAB Facilities Fee, then to the CAB Stormwater Tap Fee, then to the CAB Water Tap Fee, then to the CAB Sanitary Sewer Tap Fee due for such residential unit.

VIOLATION COMPLAINT – WITNESS STATEMENT

VIOLATION COMPLAINT - WITNESS STATEMENT

PLEASE PRINT OR TYPE. Complete all the information you know. If unknown, please state so. Attach additional sheets if necessary.

INFORMATION CONCERNING WITNESS(ES) TO VIOLATION

Reporting Witness Name _____ Date _____
Unit # _____ Area Code - Phone number _____

ADDITIONAL WITNESSES

Name & Address _____ Area Code - Phone Number _____
Name & Address _____ Area Code - Phone Number _____

INFORMATION CONCERNING THE VIOLATOR

Violator's Name _____ Area Code - Phone Number _____
Unit # _____
Unit Owner's Name, Address & Phone No. if different than the Violator. _____

INFORMATION CONCERNING THE VIOLATION

Violation Date _____ Time _____ Location _____

Section(s) of Master Declaration or Rules and Regulations that was violated _____

Reporting Witness' Observations:

Were any photographs or sound recordings made? Yes _____ No _____ By whom? _____
Include any audio or videotapes or photographs with this form or forward as soon as possible. Include the name of the person who made the tape or photograph(s), the date it was made, the location it was made and the name of anyone else who was present.

I HAVE MADE THE ABOVE STATEMENTS BASED ON MY PERSONAL KNOWLEDGE AND NOT UPON WHAT HAS BEEN TOLD TO ME. I WILL FULLY COOPERATE WITH CAB AND ITS ATTORNEYS TO PROVIDE ADDITIONAL STATEMENTS OR AFFIDAVITS, AND IN THE EVENT A HEARING OR TRIAL IS NECESSARY, I WILL _____ WILL NOT _____ APPEAR TO TESTIFY AS A WITNESS.

Signature

NOTICE OF ALLEGED VIOLATION

NOTICE OF ALLEGED VIOLATION

TO: _____
(Unit Owner/Tenant)

Date: _____

NOTICE OF ALLEGED VIOLATION

Re: Violation of Master Declaration, Bylaws or Rules and Regulations

You are hereby notified, as the Owner/Tenant of the Unit # _____ at (Address, City) _____, Colorado that you violated the Master Declaration or Rules and Regulations. The actions complained of occurred on or about _____, 20__ and are described as follows:

UNDER CAB’S RULES AND REGULATIONS, IF YOU FAIL TO REQUEST A HEARING BEFORE THE ENFORCEMENT COMMITTEE WITHIN 7 DAYS OR FAIL TO APPEAR AT A HEARING ON THESE VIOLATIONS, YOU WILL BE FOUND GUILTY BY DEFAULT, AND FINES, CHARGES, COSTS, EXPENSES AND LEGAL FEES MAY BE ASSESSED AGAINST YOU AND ADDED TO YOUR MONTHLY ASSESSMENT.

IF A VIOLATION EXISTS, WHICH HAS NOT ALREADY BEEN CORRECTED AND YOU FAIL TO MAKE AN APPROPRIATE CORRECTION, CAB MAY CORRECT THE VIOLATION AT YOUR EXPENSE.

Please consult the Master Declaration and Rules and Regulations for further details.

You may request a hearing before the Enforcement Committee by signing, dating and returning the attached Request for a Hearing form within 7 days to CAB at the address below.

Very truly yours,

STERLING RANCH COMMUNITY AUTHORITY BOARD

By: _____

Title: _____

Address

City, State, Zip

Area Code and Phone #

**REQUEST FOR A HEARING BEFORE
THE ENFORCEMENT COMMITTEE
ON NOTICE OF ALLEGED
VIOLATION**

**REQUEST FOR A HEARING BEFORE THE ENFORCEMENT COMMITTEE ON
NOTICE OF ALLEGED VIOLATION**

I hereby request a hearing before the Enforcement Committee on the statements made against me as contained in the Notice of Alleged Violation dated _____, 20____
alleging a violation of the Master Declaration or Rules and Regulations for Sterling Ranch
Planned Development.

Owner/Resident's Name (printed)

Address

City, State, Zip

Area Code and Phone #

Signature

Date

**NOTICE OF VIOLATION –
ENFORCEMENT COMMITTEE
DETERMINATION**

**NOTICE OF VIOLATION
ENFORCEMENT COMMITTEE DETERMINATION**

TO: _____
(Unit Owner/Tenant)

Date: _____

NOTICE OF DETERMINATION REGARDING VIOLATION

On _____ 20 _____ you were notified of a violation of the Master Declaration or Rules and Regulations of Sterling Ranch Planned Development. Pursuant to Rules and Regulations:

- () A hearing before the Enforcement Committee was held at your request regarding the alleged violation.
- () You have admitted to the violation by default and waived your right to request a hearing. After considering the complaint and evidence, the following determination has been made and the following action(s) will be taken:
 - () You were found not guilty and no action will be taken.
 - () A 1st, 2nd, 3rd or subsequent violation (circle one) of the Master Declaration or Rules and Regulations has occurred and a fine in the amount of \$ _____ is now due.
 - () A violation of the Master Declaration or Rules and Regulations of a continuing nature has occurred and a fine in the amount of \$ _____ per day from _____, 20 _____ is now due. A FINE FOR A CONTINUING VIOLATION WILL CONTINUE UNTIL THE VIOLATION HAS BEEN ELIMINATED AND CAB HAS BEEN NOTIFIED.
 - () Damages & expenses in the amount of \$ _____ have accrued and are due.
 - () Legal expenses in the amount of \$ _____ have been incurred by CAB and are due.
 - () Damages have occurred or an architectural violation exists, as charged in the complaint. CAB will proceed to have the damages or violation corrected or repaired at your expense.
 - () As a result of a second or subsequent violation, we have instructed our attorneys to inform you that legal proceedings will be instituted if further violations occur, and the fees and expenses incurred will be assessed to you.

**STERLING RANCH COMMUNITY
AUTHORITY BOARD**

By: _____
Title: _____
Address: _____

REQUEST FOR A HEARING BEFORE
THE CAB BOARD ON
ENFORCEMENT COMMITTEE
NOTICE OF VIOLATION

**REQUEST FOR A HEARING BEFORE THE CAB BOARD ON ENFORCEMENT
COMMITTEE NOTICE OF VIOLATION**

I hereby request a hearing before the CAB Board on the decision made by the Enforcement Committee on the matters contained in the Notice of Violation dated _____, 20____ regarding violations of the Master Declaration or Rules and Regulations for Sterling Ranch Planned Development.

Owner/Resident's Name (printed)

Address

City, State, Zip

Area Code and Phone #

Signature

Date

NOTICE OF DETERMINATION OF
CAB BOARD ON APPEAL FROM
ENFORCEMENT COMMITTEE
NOTICE OF VIOLATION

**NOTICE OF DETERMINATION OF CAB BOARD ON APPEAL FROM
ENFORCEMENT COMMITTEE NOTICE OF VIOLATION**

TO: _____
(Unit Owner/Tenant)

Date: _____

NOTICE OF DETERMINATION REGARDING VIOLATION

On _____ 20 _____ you were notified of the Notice of Violation issued by the Enforcement Committee.

- A hearing was held at your request regarding the violation.
- You have admitted to the violation by default and waived your right to request a hearing. After considering the complaint and evidence, the following determination has been made and the following action(s) will be taken:
 - You were found not guilty and no action will be taken.
 - A 1st, 2nd, 3rd or subsequent violation (circle one) of the Master Declaration or Rules and Regulations has occurred and a fine in the amount of \$_____ is now due.
 - A violation of the Master Declaration or Rules and Regulations of a continuing nature has occurred and a fine in the amount of \$_____ per day from _____, 20_____ is now due. **A FINE FOR A CONTINUING VIOLATION WILL CONTINUE UNTIL THE VIOLATION HAS BEEN ELIMINATED AND CAB HAS BEEN NOTIFIED.**
 - Damages & expenses in the amount of \$_____ have accrued and are due.
 - Legal expenses in the amount of \$_____ have been incurred by CAB and are due.
 - Damages have occurred or an architectural violation exists, as charged in the complaint. CAB will proceed to have the damages or violation corrected or repaired at your expense.
 - As a result of a second or subsequent violation, we have instructed our attorneys to inform you that legal proceedings will be instituted if further violations occur, and the fees and expenses incurred will be assessed to you.

**STERLING RANCH COMMUNITY
AUTHORITY BOARD**

By: _____
Title: _____
Address: _____

**REQUEST FOR A HEARING BEFORE
THE CAB BOARD APPEALING
DESIGN REVIEW COMMITTEE
DENIAL OF VARIANCE**

**REQUEST FOR A HEARING BEFORE THE CAB BOARD APPEALING DESIGN
REVIEW COMMITTEE DENIAL OF A VARIANCE**

I hereby request a hearing before the CAB Board on the decision made by the Design Review Committee denying my request for a variance from the Design Guidelines.

Owner/Resident's Name (printed)

Address

City, State, Zip

Area Code and Phone #

Signature

Date

WATER AND SEWER CONNECTION INSTRUCTIONS



STERLING RANCH
C O L O R A D O

STERLING RANCH COMMUNITY AUTHORITY BOARD

8390 E. Crescent Parkway, Suite 500
Greenwood Village, CO 80111
Ph: (303) 779-5710
Fax: (303) 779-0348

www.SterlingRanchColorado.com

Water and Sewer Connection Instructions:

A Water and Sewer Connection Permit is required before any digging can take place.

Utility locates are required by law – call Utility Notification Center of Colorado at 1-800-922-1987

Sterling Ranch Community Authority Board (CAB) Rules and Regulations:

Purchase of a Water and Sewer Connection Permit obligates the Owner and Owner’s Contractor, to strictly adhere to all of the CAB Rules and Regulations that pertain to water and sewer service line connections. Exceptions to the CAB’s Rules and Regulations may be made only upon application and approval in writing by the CAB Manager.

The information needed is covered in:

1. CAB Rules and Regulations – Utilities
2. CAB Rules and Regulations – Utilities, Parks and Open Space
3. CAB Technical Standards and Specifications for Potable Water, Sanitary Sewer and Non-Potable Water – March, 2017

They are available on the CAB’s website at www.SterlingRanchColorado.com, in the CAB office to read, or they may be purchased for a fee.

Insurance Requirements:

No one shall commence work pursuant to any permit until he has obtained and delivered to the CAB Management Office, all required insurance. Prior to the commencement of any work under the permit, the contractor and or subcontractor shall furnish to the CAB certificates of insurance to prove that all required insurance is current and in force. All insurance policies shall list the CAB as an additional insured.

Commercial General Liability:

General Aggregate	\$2,000,000
Products and Completed Operations	\$1,000,000
Personal & Advertising Injury	\$1,000,000
Each Occurrence	\$1,000,000

Comprehensive Automobile Liability:

Coverage shall include all motor vehicles owned, hired, leased, or borrowed with a minimum combined single limit for bodily injury and property damage of not less than \$1,000,000 each occurrence, \$1,000,000 aggregate.

Umbrella Policy: \$1,000,000

Coverage to be in excess of the commercial general liability and automobile liability limits.

Installers General Water and Sewer Connection Instructions:

The following instructions will help you and the CAB in getting your water and sewer connections made with a minimum of difficulty and are not intended to replace or supersede any information in the CAB Rules and Regulations. These instructions are general in nature and will not cover all situations that may arise during the connection process. If at any time a problem or question occurs, please be sure to contact the CAB Billing Office for instructions before proceeding with a connection. Conflicts will be governed by the Rules and Regulations. Contact the CAB Billing Office at 303-779-5710 and the Utility Notification Center of Colorado at 1-800- 922-1987 at least two (2) business days' notice prior to any kind of water and sewer excavation in order for the CAB to locate water, sewer and for other existing utilities in the area to be located.

1. Water Line Installation and Connection:

- a. A "Water and Sewer Connection Permit" must be obtained and \$100 fee to be paid before any excavation takes place for the water line service.
- b. Owner's contractor must give the CAB Billing Office two (2) business days' notice prior to inspection by calling the CAB Billing Office at 303-779-5710.
- c. The owner shall supply all materials including the water meter.
- d. Water services shall be adequately sized to meet the requirements of the facility being served as determined by the CAB General Manager. The minimum water service line shall be three-quarter inch (3/4"). The service line and meter shall be sized according to AWWA Manual M22: "Sizing Water Service Lines and Meters".
- e. Water service lines shall be seamless copper tube, type K, three quarter inch (3/4"). All connection fittings shall be of the flare type.
- f. Curb stops shall be buried a minimum of four and a half feet (4.5') and a maximum of six feet (6'). The curb stop box shall be a minimum of two inches (2") and a maximum of four inches (4") above final grade or back of sidewalk. When the curb stop box is located in a driveway, it shall be flush with the finish grade of the concrete and isolated with expansion material. Refer to Detail WS-4 on page 6.
- g. If any portion of the service line is to be located under a hard surface such as a driveway, then the service line shall be sleeved in C900 pipe. If in doubt, consult the CAB's Billing Manager at 303-779-5710.
- h. Water service lines shall be a minimum of four and a half feet (4.5') deep. The bedding shall be a minimum of three inches (3") below the water line and three inches (3") over the water line. Bedding shall be Class A or Squeegee.

Trenches shall remain open until the CAB Billing Office can cause all installations to be inspected. No partial inspection for water and sewer service line installations will be permitted without prior written approval by the CAB General Manager.

If the water and/or sanitary services are not installed as per the instruction brochure (or specs & standards), then an 'as-built' of the services shall be submitted to the CAB for review and approval. As-builts shall show the complete service from sanitary service stub or water service curb stop, show any applicable bends, show where the service enters the house complete with measurements to a fixed point on the foundation or other permanent object.

2. Sewer Line Installation and Connection:

- a. A Water and Sewer Connection Permit must be obtained and a \$100 fee paid before any excavation takes place for the sewer line service.
- b. Owner's contractor must give the CAB Billing Office two (2) business days' notice prior to inspection by calling the CAB Billing Office at 303-779-5710.
- c. The Owner shall supply all the materials for the sewer line connection.
- d. Sewer service lines shall be constructed in the shortest and straightest route possible,

using ASTM 3034 SDR 35 plastic pipe or the equivalent. Service lines shall be installed in accordance with UBC and UPC standards. A sewer cleanout shall be installed within three feet (3') of the exit point of the sewer service line from the structure and every one hundred feet (100') thereafter. Refer to Detail SS-2 on page 9.

- e. If any portion of the service line is located under a hard surface such as a driveway, the use of C900 pipe will be required. SDR 35 to C900 transitions are allowed.
- f. Sewer service lines shall be a minimum of five feet (5') deep. The bedding shall be a minimum of six inches (6") below the sewer line and six inches (6") over the sewer line. Bedding shall be Class A or Squeegee.
- g. Common trenching is allowed. Trenches shall remain open until the CAB Billing Office causes all installations to be inspected. No partial inspection for water and sewer line installations will be permitted without prior written approval of the CAB Manager.

If the water and/or sanitary services are not installed as per the instruction brochure (or specs & standards), then an 'as-built' of the services shall be submitted to the CAB for review and approval. As-builts shall show the complete service from sanitary service stub or water service curb stop, show any applicable bends, show where the service enters the house complete with measurements to a fixed point on the foundation or other permanent object.







3. Water Meter Installation:

- a. Owner is responsible for providing and installing the meter setter and associated plumbing. A \$100 fee is to be paid for a multi-family (single meter) and a \$150 is to be paid for a single family residence (double meter) prior to inspection of meter sets.
- b. All inside plumbing will follow water meter detail WS-5 & 600 on page 7 & 8. The following shall be installed after the service enters the structure and prior to the meter panel:
 - 1. Three-quarter inch (3/4") stop and waste ball valve, which is readily available, where the water line comes into the structure.
 - 2. A pressure regulator – Watts Model LFAUB25, between the stop and waste ball valve and the meter panel.
- c. Siemens meter information and ordering details shown on pages 10-13.
- d. Payment of the water meter fee shall be made at the CAB Billing Office. The water meter shall be picked up at the location designated by the CAB Billing Office. See detail as shown on Drawing 600.
- e. Meter sets shall be inspected at the direction of the CAB Billing Services by calling the CAB Billing Services at 303-779-5710 at least two (2) business days in advance. Note: If meter cannot be set due to improper installation, an additional \$100 fee shall be assessed for each return inspection. All meters shall be installed prior to receipt of a Certificate of Occupancy from the Douglas County Building Department. Failure to install a meter prior to receiving the required Certificate of Occupancy shall be subject to a \$1,000 fine, assessed by the CAB. Meter sets in cold months must have a permanent heat source available.
- f. Jumpers are not allowed. Un-metered water use is prohibited without written permission from the CAB. If this provision is violated, the owner of the offending service shall be immediately assessed a \$300 fine per incident.
- g. The Owner will purchase, supply and install the water meter from Siemens, and the CAB will maintain the water meter. The CAB Management Office will cause the meter to be inspected, tested, calibrated and commissioned after installation is complete. It is the Owner's responsibility to ensure that the water billing address is

correct and bills are paid promptly. The Owner shall notify the CAB Management Office of any change of ownership or of any change of billing responsibility by calling 303-779-5710. Owners must allow CAB representatives to access the water and sewer services upon request. (Please refer to CAB Rules and Regulations).

4. Backflow Prevention Device Testing:
 - a. Owner is responsible for installing the Backflow Prevention Device. An inspection by the CAB is required prior to operation of the irrigation system. A \$150 fee is to be paid prior to inspection of Backflow Prevention Device.
 - b. Owner's contractor must give the CAB two (2) business days' notice prior to inspection by calling the CAB at 303-779-5710.

REMINDERS

-  A Water and Sewer Connection Permit is required before any digging can take place.
-  Insurance requirements and certificates of insurance must be met and provided prior to the commencement of any work.
-  Utility locates must be requested.
-  If at any time a problem or questions occur, please be sure to contact the CAB Billing Office by calling 303-779-5710 for instructions before proceeding with a connection.
-  Jumpers are not allowed. Un-metered water is prohibited.
-  Any variances must be requested in writing and approved by the CAB General Manager in writing prior to excavation.
-  CAB Rules and Regulations are available at www.SterlingRanchColorado.com, or in the CAB's office.

Drawing WS-4

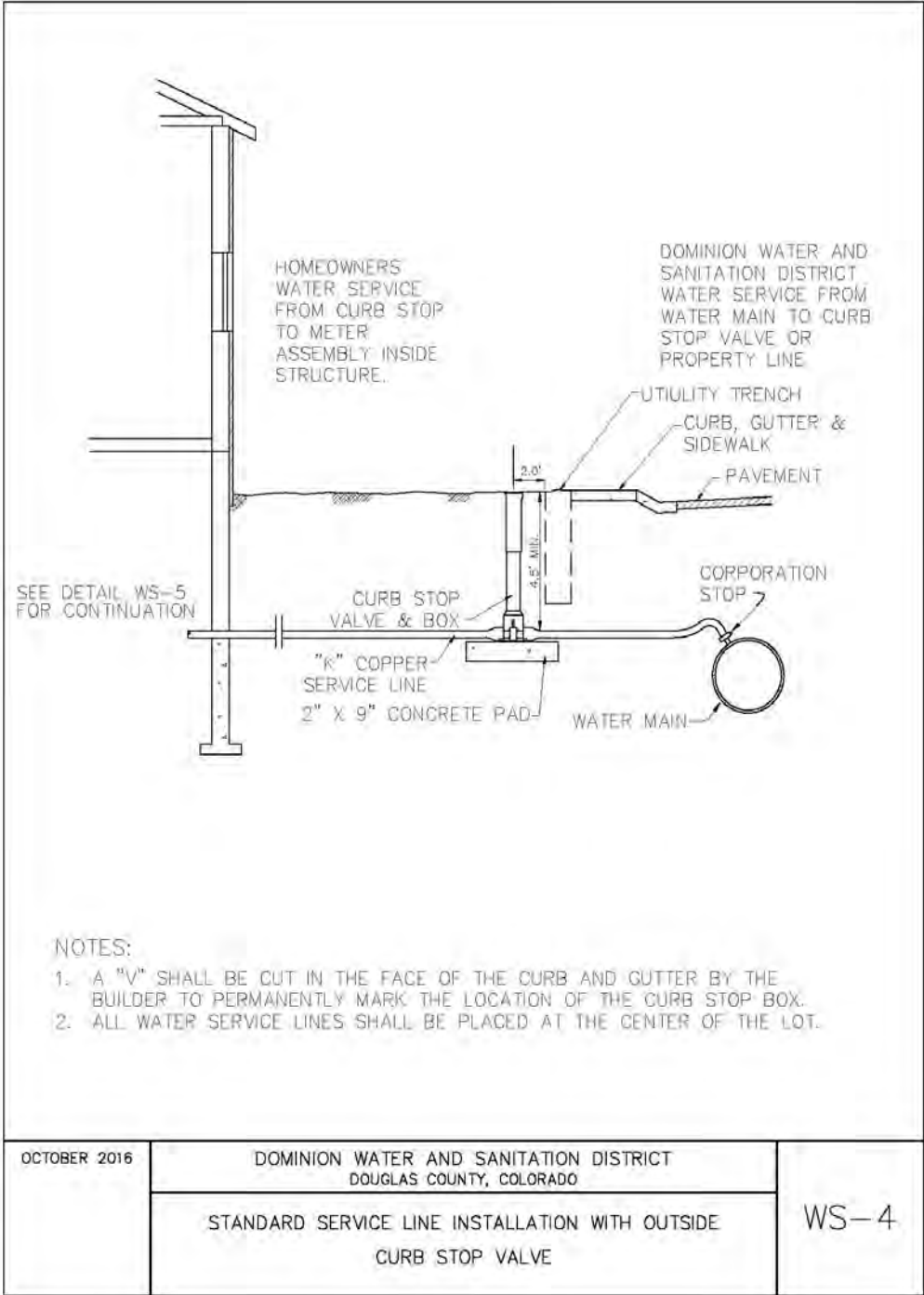

Drawing WS-5

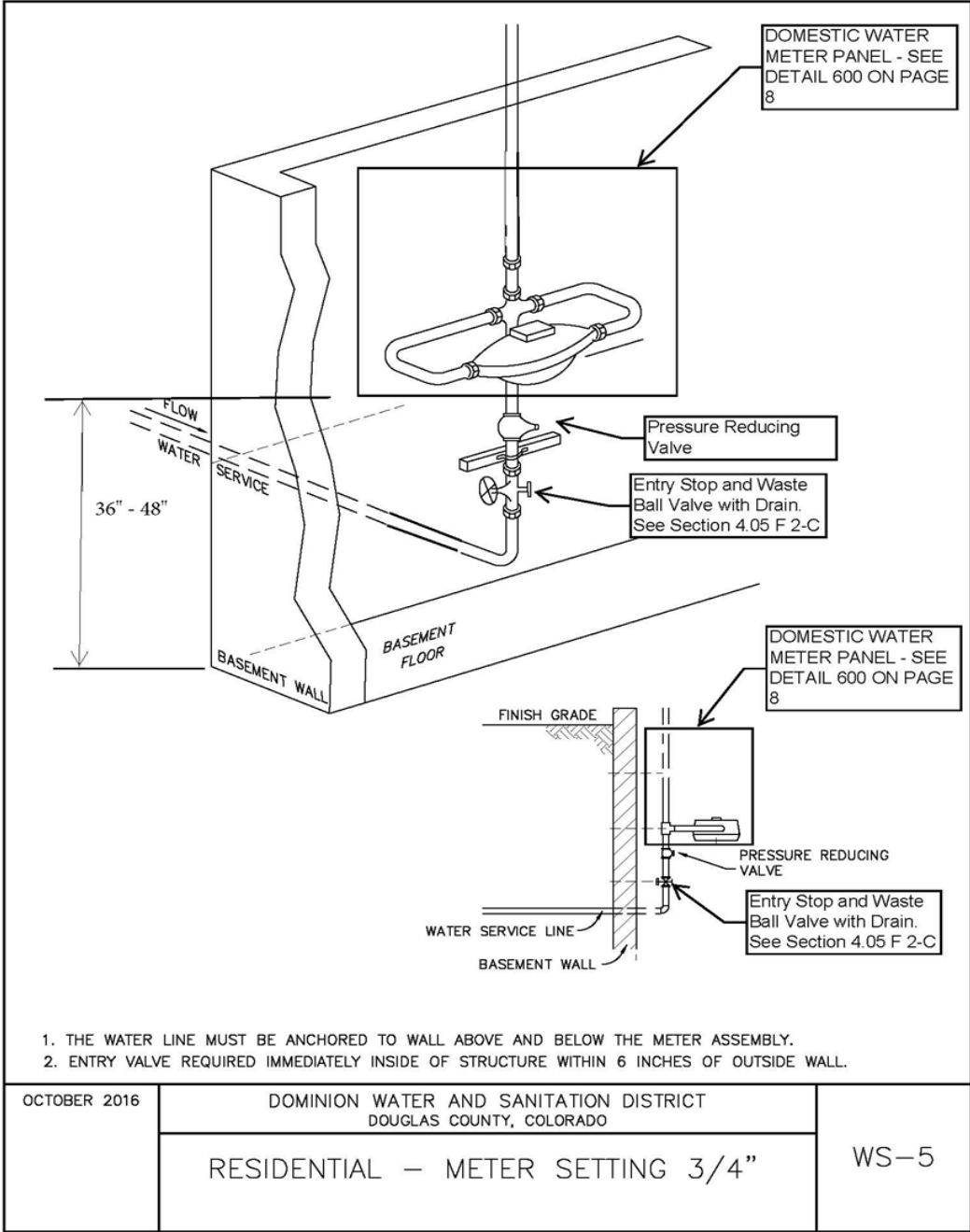

Drawing 600

INSTALLATION NOTES:

1. 3/4" MANUAL BALL VALVE (BV-1). PROVIDED BY PANEL BUILDER.
2. 3/4" TO 1" ADAPTER (ADPT-1). PROVIDED BY PANEL BUILDER.
3. 3/4" TEE (ADPT-2). PROVIDED BY PANEL BUILDER.
4. SENSUS FLOW METER PROVIDED BY SIEMENS. (1" MALE THREADED)
5. SOLENOID VALVES PROVIDED BY SIEMENS. (3/4" FEMALE THREADED)
6. MOUNT FOR 3/4" PEX TUBING (ADPT-3). PROVIDED BY PANEL BUILDER.
7. DEVICES IN ELECTRICAL SEPARATION BOX PROVIDED BY SIEMENS. ALL WIRING TO THESE DEVICES BY PANEL BUILDER.
8. ALL TERMINATIONS INSIDE THE PUNCH DOWN BLOCK MUST BE MADE USING A PUNCH DOWN TOOL TO AVOID DAMAGING THE TERMINALS.
9. WIRE FERRULES REQUIRED ON ALL CAT5 "END DEVICE" TERMINATIONS.

DESIGNATION	QTY	PART NUMBER	DESCRIPTION
M-1	1	12T20A0K	3/4" ELECTROMAGNETIC FLOW METER
M-2	1	12T20A0K	3/4" ELECTROMAGNETIC FLOW METER
V-1	1	8512A03BL0100F2	3/4" NPT 120V 2 POS (ASCO)
V-2	1	8512A03BL0100F2	3/4" NPT 120V 2 POS (ASCO)
PNL-1	1	-	FABRICATED WATER METER PANEL
DR-1	1	-	FABRICATED WATER METER PANEL DOOR
POB-1	1	7091	SURFACE MOUNT BOX CAT5 DOUBLE JACK
RE-1	1	JRF2120-1A1V2	2 CHANNEL 1-30VDC RELAY
RE-2	1	385720-1A442	2 CHANNEL 4-30VDC RELAY

DESIGNATION	QTY	PART NUMBER	DESCRIPTION
BV-1	4	-	3/4" MANUAL BALL VALVE
ADPT-1	4	-	3/4" TO 1" THREADED ADAPTER
ADPT-2	1	-	3/4" TEE FOR PEX TUBING
ADPT-3	4	-	MOUNT FOR PEX TUBING
TUBING	1	-	3/4" PEX TUBING
WIRING	1	-	ALL CAT5 & 120VAC WIRING AS SHOWN



STERLING RANCH COLLEGE



ELECTRICAL SEPARATION WIRING DETAIL

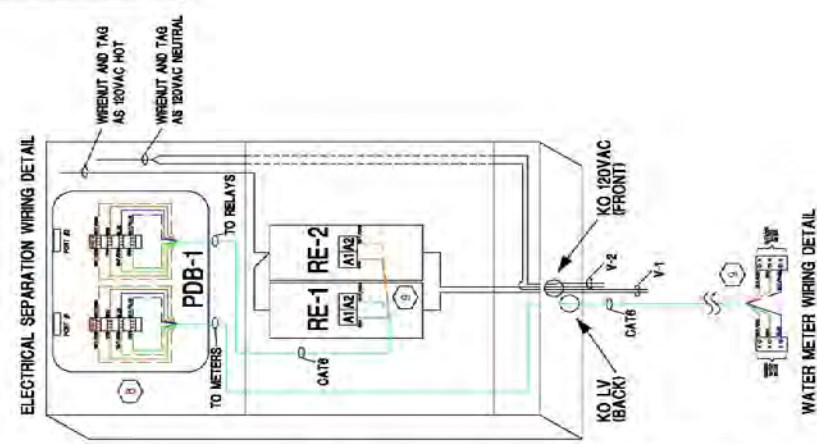

REVISION HISTORY

REV	SLC	REV	DATE	DESCRIPTION
01	SLC	01	09/19/16	09/19/16

7810 SHAFER PKWY
STE 100
LITTLETON, CO 80187
USA
Phone: 303-278-6500
Fax:

STERLING RANCH HOME AUTOMATION
STERLING RANCH, CO
600
DOMESTIC WATER PANEL



SIEMENS

SIEMENS INDUSTRY, INC.
 BUILDING TECHNOLOGIES

© COPYRIGHT 2016 SIEMENS INDUSTRY, INC. ALL RIGHTS RESERVED.

Drawing SS-2

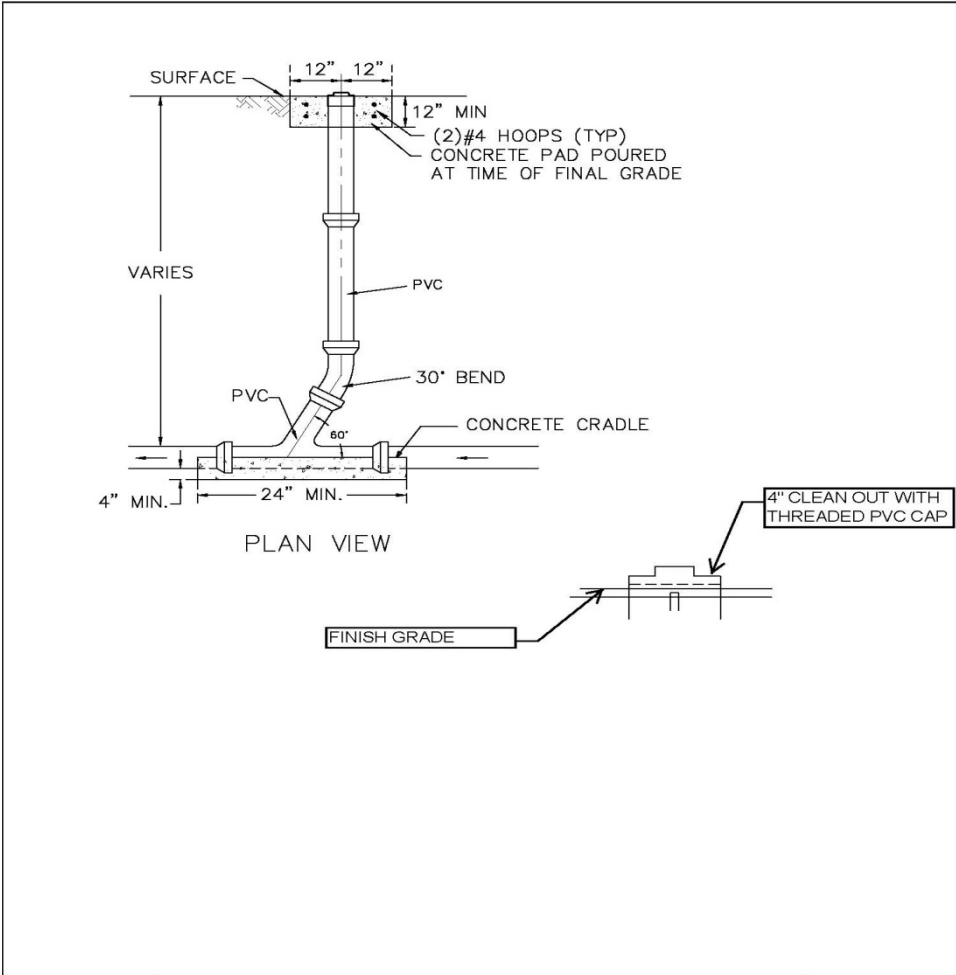

OCTOBER 2016	DOMINION WATER AND SANITATION DISTRICT DOUGLAS COUNTY, COLORADO	
	IN-LINE SANITARY SEWER CLEANOUTS (4" & 6")	SS-2

SIEMENS WATER METER INSTALLATION INFORMATION

Assumptions:

1. Fiber will be available at the home and an ONT will be used to provide an available Ethernet cable.
2. CAT5E network drops and any other associated network patch cables will be provided by others.
3. Dedicated electric power circuits and receptacles specified in this document will be provided by others.
4. Indoor water backflow preventer will be provided and installed by others.
5. Outdoor water backflow preventer will be provided and installed by others.
6. Main incoming water line isolation manual ball valve will be provided and installed by others.
7. Main incoming water line pressure reducing valve will be provided and installed by others.
8. The Siemens water metering enclosure will have three connection points. One for the main water line incoming connection, one indoor water outgoing connection, and one outdoor water outgoing connection. All these three connections will be connected by others.

Constraints:

1. Cat5E network cable cannot exceed 100 meters (328 feet)
2. Indoor and Outdoor water meter three conductor stranded 18AWG cable cannot exceed 400ft in length.
3. Indoor and Outdoor electronic water valves two conductor stranded 18AWG cable cannot exceed 200ft in length.

Dependencies:

1. Water lines must be connected and flowing water.
2. Electrical power must be ready and hot to the water metering enclosure receptacle.
3. Network drop must be terminated at the water metering enclosure and active on the community fiber network.

Communication/Protocol:

1. SCADAmetrics Ethermeter Gateway will communicate to DESIGO CC via BACnet/IP

Bill of Material:

Siemens will provide one orderable part number for each metering solution. Each packaged metering solution will contain the following:

Hardware:

WBS: 1.1.1.4.1.1 and 1.1.1.4.1.2 Name: Water Meter Station

Qty	Product Number:	Product Description	Manufacturer/Supplier
1	MGT2421DV	Dual Voltage 24VAC, 12VDC Power Supply	MG Electronics
1	SRWMP1	Custom Water Metering Enclosure	Siemens
1	107-403NL	1/2 inch Forged-Brass FPT Ball Valve	Mueller Global
4	164-135HC	1 inch SCH 80 PVC FPT x FPT Union	Mueller Global
4	22182-0000LF	1/2 inch Brass Push-Fit x FNPT Ball Valve	SharkBite
4	38081	1/2 inch x Close PVC Riser	Orbit
2	38108	1 inch x 6 inch PVC Riser	Orbit
2	599-10316	1-inch 2-Way Ball Valve N/C 2-POS	Siemens
1	EM-100	Ethermeter Flow Meter Gateway	Scadametrics
2	GMA121.1P	2P ACT SR Plenum 24 VAC/DC 120VAC	Siemens
2	iPERL	Electromagnetic Flow Measurement System	Sensus
2	LFA833	1/2 inch Lead-Free Brass Hex Nipple	Watts
1	U120LFA	1/2 inch Brass Push-Fit x MNPT Adapter	SharkBite
3	U248LFA	1/2 inch Brass 90-Degree Push-Fit Elbow	SharkBite
1	U3362LFA	1/2 inch Brass Push-Fit Slip Tee	SharkBite
1	U3482LFA	1/2 inch Brass Push-Fit x Push-Fit x FNPT Slip Tee	SharkBite
1	U860B5	1/2 inch x 5 Feet Blue PEX Pipe	SharkBite

Warranty:

Product Number:	Product Description	Manufacturer/Supplier	Warranty
MGT2412DV	Dual Voltage 24VAC, 12VDC Power Supply	MG Electronics	2 Year
SRWMP1	Custom Water Metering Enclosure	Siemens	2 Year
107-403NL	1/2 inch Forged-Brass FPT Ball Valve	Mueller Global	2 Year
164-135HC	1 inch SCH 80 PVC FPT x FPT Union	Mueller Global	2 Year
22182-0000LF	1/2 inch Brass Push-Fit x FNPT Ball Valve	SharkBite	25 Year
38081	1/2 inch x Close PVC Riser	Orbit	2 Year
38108	1 inch x 6 inch PVC Riser	Orbit	2 Year
599-10316	1-inch 2-Way Ball Valve N/C 2-POS	Siemens	2 Year
EM-100	Ethermeter Flow Meter Gateway	Scadameetrics	2 Year
GMA121.1P	2P ACT SR Plenum 24 VAC/DC 120VAC	Siemens	2 Year
iPERL	Electromagnetic Flow Measurement System	Sensus	20 Years
LFA833	1/2 inch Lead-Free Brass Hex Nipple	Watts	2 Year
U120LFA	1/2 inch Brass Push-Fit x MNPT Adapter	SharkBite	25 Year
U248LFA	1/2 inch Brass 90-Degree Push-Fit Elbow	SharkBite	25 Year
U3362LFA	1/2 inch Brass Push-Fit Slip Tee	SharkBite	25 Year
U3482LFA	1/2 inch Brass Push-Fit x Push-Fit x FNPT Slip Tee	SharkBite	25 Year
U860B5	1/2 inch x 5 Feet Blue PEX Pipe	SharkBite	25 Year

Home Builder Responsibilities:

1. Home Builder will be responsible for taking possession of the water metering package.
2. Home Builder will be responsible for installation of the water metering package on behalf of the CAB.
3. Home Builder will be responsible for providing final water connections to water metering package.
4. Home Builder will be responsible for providing electrical power to the water metering package.
5. Home Builder will be responsible for providing network wiring and connections to metering package.
6. Home Builder will be responsible for scheduling Siemens for commissioning of the water metering package after network and electric power is available with no less than 48 hours prior notice (2 working days).

7. Home Builder will be responsible for contacting Siemens with any home owner warranty claims.

Ordering Process:

1. Water metering packages will be on a pallet and shrink wrapped and delivered to site.
2. Purchase order must be provided at the time of ordering.
3. The lead time between the placement of an order and delivery may be from 3 weeks to 1 month.
4. Invoicing will be provided at the time of delivery; payment method will be NET30.

Install Process:

1. Siemens water metering package was designed to be installed in the basement mechanical closet in between wall studs.
2. All internal wiring between water meters and electric valve actuators and Siemens provided controller will be responsibility of Siemens. This excludes electric power and network connection that will be responsibility of the home builder.

Commissioning Process:

1. Once the water metering package is installed and wired with network and electric power. Siemens will need to commission the water metering package. Commissioning will include:
 - a. Verification of proper install
 - b. Verification of proper wiring
 - c. Configuration of controller
 - d. Verification of local water meter readings
 - e. Verification of water valve electric actuator operation
 - f. Verification of full control and monitoring from community management system DESIGO CC
2. The commissioning process will take about 1 hour by a trained Siemens Specialist. This commissioning process is associated with the CAB inspections and can be performed at any time after: the install of the water metering package, network and electric power are available, and before home owner move-in.

STERLING RANCH COMMUNITY AUTHORITY BOARD PERMIT TO CONNECT TO WATER & SEWER SERVICES

Date of Application: _____

Date of Expiration¹: _____

The undersigned hereby applies for permission to connect to the water and sewer system serving the Sterling Ranch Community Authority Board (CAB) for the property located at the Service Address below and expressly agrees to adhere to the Rules and Regulations of CAB and further grants CAB and its Agents the right of ingress and egress over said property for inspection and other CAB related activities. The undersigned agrees to pay all costs imposed by CAB including all fees as calculated by the General Manager.

Owner's Name: _____

Phone: _____

Address: _____

Service Address: _____

Legal Description: Subdivision: _____

Filing No.: _____ Lot No.: _____

Connection Fees (all fees for all inspections are due in aggregate at the time of application)

Single Family Residence (**double** meter): ____ Commercial (**double** meter): ____ Multi-Family (**single** meter): ____

Water Meter Size: ¾" Other Meter Size: _____

Fees:

- Water Connection Inspection \$100 \$ _____
- Sewer Connection Inspection \$100 \$ _____
- Single** Meter Connection Inspection \$100 \$ _____
- Dual** Meter Connection Inspection \$150 \$ _____
- Backflow Prevention Device Inspection \$150 \$ _____
- Final Meter Installation Inspection \$100 \$ _____

TOTAL FEES: \$ _____

Other Requirements:

Proof of Insurance (attached)

***NOTE: Sanitary cleanout cap elevation to be inspected when final grade is achieved.**

PAID BY CHECK NO.: _____ DATE PAID: _____ AMOUNT: \$ _____

In the event connection to the CAB's infrastructure as referenced above is not ACTIVATED within ONE YEAR of purchase date from the CAB, this Permit shall become VOID and all rights shall revert to the CAB. For the purposes of this Permit, the connections shall be considered activated upon completion of its installation together with the inspection and acceptance of the installation by the CAB or its designated representative.

Note: Owner must notify the General Manager, (phone 303.779.5710), two (2) business days in advance to make an appointment for the inspection of tap connection.

¹ If connection has not been made by the expiration date, property may be subject to an increase in tap fees.

**STERLING RANCH COMMUNITY AUTHORITY BOARD
PERMIT TO CONNECT TO WATER & SEWER SERVICES**

APPLICANT SIGNATURE _____ DATE: _____

Lot No. _____ Builder: _____

Service Address: _____

STERLING RANCH COMMUNITY AUTHORITY BOARD ("CAB")

Permission has been granted by the CAB to initiate connection to the water and sewer system.

AGENT _____ DATE: _____

PERMIT VALID IF SIGNED BY AUTHORIZED REPRESENTATIVE

FOR AUTHORITY'S USE ONLY

Application / Payment Date: _____, Received by: _____

Engineer Notification Date: _____, Notified by: _____

Water Connection Inspection Date²: _____, Inspected by: _____

Sewer Connection Inspection Date: _____, Inspected by: _____

Meter Connection Inspection Date: _____, Inspected by: _____

Backflow Prevention Device Inspection Date: _____, Inspected by: _____

San Cleanout Cap Elevation Insp Date³: _____, Inspected by: _____

Final Meter Installation Insp Date: _____, Inspected by: _____

Fees Paid:

Water Connection Fee (tap) Water Connection Inspection Fee

Sewer Connection Fee (tap) Sewer Connection Inspection Fee

Facility Fees Meter Connection Inspection Fee

Inspection of Final Meter Installation Fee Backflow Prevention Device Inspection Fee

FOR BILLING SERVICES USE ONLY

Billing Set-up Date: _____, Set Up by: _____

Meter Serial Nos.: Indoor: _____, Outdoor: _____

Assigned Location Identifier: _____

² See documentation from Operator/Engineer

³ To be scheduled after final grade is achieved – no additional fee will be charged for this inspection

LANDSCAPE INSPECTIONS AND INSTRUCTIONS



INSTRUCTIONS FOR LANDSCAPE INSPECTIONS

The **Sterling Ranch Water Demand Management Initiatives** * specify that soil amendment must be inspected prior to planting. This is to verify amendments have been incorporated into the soil in the quantity specified and to the depth required. Per the Water Demand Management Initiatives, the specification is 4 cubic yards of soil amendment for each 1000 square feet, tilled to a depth of 6 inches. Soil Amendment must be a combination of aged ground manure and compost.

A second inspection will be performed after irrigation and plantings are complete in order to verify that the installed material is in substantial conformance with the approved plans, and that the irrigation system is active and in substantial conformance with the approved plans.

The fee payment for these inspections is as follows:

- \$100.00 This fee covers both Soil Amendment Inspection and Landscape/Irrigation Inspection
- Fee Payments should be made payable to Sterling Ranch Community Authority and sent to:
Sterling Ranch Community Authority
c/o Clifton Larson Allen
8390 East Crescent Parkway, Suite 500
Greenwood Village CO 80111

TO SCHEDULE AN INSPECTION

(MINIMUM 24 HOURS NOTICE, MONDAY THROUGH FRIDAY):

BRANDON SUKALSKI AT sukalski@corecivil.com

**Provide your name, phone number, and email address
plus the address of the property to be inspected.**

* If you do not have a copy of the Water Demand Management Initiatives, please contact us via submit@sterlingranchdrc.com to request one.

STERLING RANCH COMMUNITY AUTHORITY BOARD
POLICIES, PROCEDURES, FEES AND FORMS FOR THE
COLORADO PARKS AND WILDLIFE PARKS PASS PROGRAM

The Sterling Ranch Community Authority Board is an authority and separate legal entity formed pursuant to Section 29-1-203, C.R.S. (the “CAB”). The CAB was organized to provide certain services on behalf of users within the Sterling Ranch Planned Development (the “Community”), including but not limited to, park and recreation services.

The CAB has entered into a Parks Pass Program Agreement, dated August 15, 2017, as may be amended from time to time (the “Parks Pass Agreement”) with the Colorado Parks Foundation, Inc., a Colorado nonprofit corporation (“CPF”), to purchase Colorado Parks and Wildlife (“CPW”) annual state parks passes (each, an “Annual Pass” and together, the “Annual Passes”) for certain residents of the Community (the “Parks Pass Program”).

The Parks Pass Program is subject to the following Policies, Procedures, Fees, and Forms.

DISTRIBUTION OF ANNUAL PASSES:

Event	Distribution Method
The first 100 closings of real estate purchase agreements for “Qualified Residences” (any single family residence, townhome or condo located within the Community)	A Voucher (see sample attached as Exhibit A) to obtain an Annual Pass will be included in a welcoming packet and/or gift that will be given to the property owner of record. The Voucher must be brought to the Sterling Ranch Information Center and exchanged for an Annual Pass.
Closings for initial owners of Qualified Residences, other than the first 100 closings	A Voucher to obtain an Annual Pass will be mailed to the property owner of record and/or will be given to the real estate agent to give to the property owner. The Voucher must be brought to the Sterling Ranch Information Center and exchanged for an Annual Pass.
Closings of Qualified Residences other than for initial owners (transfer of ownership of Qualified Residences)	The property owner of record must submit an Application (Exhibit B) and submit it to the CAB at the Sterling Ranch Information Center. Once the Application is approved, the CAB will provide an Annual Pass to the Qualified Residence.
Expiration of Annual Pass	Each Annual Pass is issued for a period of one year. Owners of Qualified Residences may submit an Application for a new Annual Pass upon expiration of the initial or immediately preceding Annual Pass. Once the Application is approved, the CAB will provide an Annual Pass to the Qualified Residence.
<u>NOTE: BEFORE THE CAB PROVIDES AN ANNUAL PASS (WHETHER IN EXCHANGE FOR A VOUCHER OR FOLLOWING AN APPROVED APPLICATION), THE CAB WILL REQUIRE PRESENTATION OF GOVERNMENT-ISSUED PHOTO IDENTIFICATION AND DOCUMENTATION OF OWNERSHIP (DISCUSSED BELOW)</u>	

RULES, REGULATIONS, AND CONDITIONS

1. **PARKS PASS AGREEMENT CONTROLS.** In the event these Policies, Procedures, Fees and Forms for the Colorado Parks and Wildlife Parks Pass Program are inconsistent with the Parks Pass Agreement, the Parks Pass Agreement controls.
2. **ANNUAL PASS TERMS, CONDITIONS, LIMITATIONS AND RESTRICTIONS.** The Annual Passes are issued by CPF and may be subject to additional terms, conditions, limitations and restrictions adopted by CPF. It is the responsibility of each Annual Pass holder to comply with such terms, conditions, limitations and restrictions. The CAB shall not be liable for the failure of an Annual Pass holder to comply with such terms, conditions, limitations and restrictions.

3. LOST OR MISPLACED VOUCHERS OR ANNUAL PASSES. Each Qualified Residence is allowed one (1) Annual Pass per year. The CAB will not honor or replace lost, stolen or misplaced Vouchers or Annual Passes. PLEASE KEEP YOUR VOUCHER AND ANNUAL PASS IN A SAFE PLACE.
4. NOT TRANSFERRABLE. The CAB will provide Annual Passes for only Qualified Residences. VOUCHERS AND ANNUAL PASSES ARE NOT TRANSFERRABLE.
5. GOVERNMENT-ISSUED PHOTO IDENTIFICATION. The CAB will require presentation of government-issued photo identification (e.g., government-issued driver's license, identification card, military identification card, passport) in order to confirm the identity of the individual presenting a Voucher or submitting an Application.
6. DOCUMENTATION OF OWNERSHIP. The CAB will require presentation of documentation showing that the individual presenting a Voucher or submitting an Application is the record property owner of a Qualified Residence (e.g., deed of trust).
7. FEE FOR APPLICATION. The CAB reserves the right to charge a nominal fee for processing Applications.
8. AMENDMENT OR MODIFICATION. The CAB reserves the right to amend or modify these Policies, Procedures, Fees and Forms for the Colorado Parks and Wildlife Parks Pass Program.

EXHIBIT A

SAMPLE VOUCHER



**Bring this voucher into the
Sterling Ranch Information Center
to receive your household's annual
Colorado State Park Pass.**

Sterling Ranch believes for every walk of life, a natural journey is right outside the door. That's why we're giving every household here an annual Colorado State Parks Pass.*

Come claim your pass: Information Center, 8220 Piney River Avenue.
Please bring proof of your residency at Sterling Ranch.

Chatfield State Park and Roxborough State Park are right next door.
And there are 40 other State Parks to explore.
For more information, visit: <http://cpw.state.co.us>

**One pass per household, per year*

EXHIBIT B

APPLICATION FOR COLORADO PARKS AND WILDLIFE PARKS PASS PROGRAM

I. APPLICANT INFORMATION (Applicant to Complete Section I.)			
Applicant Name:			
Address of Qualified Residence:			
Date of Ownership of Qualified Residence:			
Cell #:		Bus. Phone #:	
Email Address:			

II. RECEIPT OF SUPPORTING DOCUMENTATION (CAB Representative to Check Appropriate Box in Section II.)	
Government-issued photo identification	<input type="checkbox"/> YES <input type="checkbox"/> NO
Proof of ownership of a Qualified Residence	<input type="checkbox"/> YES <input type="checkbox"/> NO
CAB Representative Name	
CAB Representative Signature	

III. FEES	
Application processing	\$
TOTAL	\$

IV. ANNUAL PASS(ES) ISSUED		
Annual Pass Number	Annual Pass Effective Dates	Signature of Applicant Confirming Receipt of Annual Pass

STERLING RANCH COMMUNITY AUTHORITY
BOARD POLICIES, PROCEDURES, FEES AND FORMS FOR USE OF
STERLING RANCH INFORMATION CENTER

The Sterling Ranch Information Center (the “**Facility**”) is owned and operated by the Sterling Ranch Community Authority Board, an authority and separate legal entity formed pursuant to Section 29-1-203, C.R.S. (the “**CAB**”). The Facility may be used for events and gatherings subject to the following Policies, Procedures, Fees, and Forms. The organizer of any event shall hereinafter be referred to as the Event Host.

AVAILABLE HOURS AND FEES FOR USE OF THE FACILITY ARE AS FOLLOWS:

Monday through Friday Noon – 6:00 p.m.	1 – 6 people	Non-Refundable User Fee • No Fees For Use in 2017 or 2018 Being Imposed At This Time	No Deposit Required
Monday through Friday Noon – 6:00 p.m.	7 – 12 people	Non-Refundable User Fee • No Fees For Use in 2017 or 2018 Being Imposed At This Time	No Deposit Required for 2017 or 2018 At This Time
Monday through Friday 8:00 a.m. – Noon 6:00 p.m. – 8:00 p.m. Saturday 8:00 a.m. – 10:00 a.m. 6:00 p.m. – 8:00 p.m. Sunday 6:00 p.m. – 8:00 p.m.	1 – 49 people	Non-Refundable User Fee • No Fees For Use in 2017 or 2018 Being Imposed At This Time	No Deposit Required for 2017 or 2018 At This Time
The CAB, in its sole discretion, reserves the right to limit the length of any event, to limit the number of events, and to limit events or the hours of events based on availability of staffing.			

RULES, REGULATIONS, AND CONDITIONS

9. **MAXIMUM OCCUPANCY** of Building is limited to 49 people.
10. **RESERVATIONS**. Minimum 72 hours Advance Notice is required to secure a reservation for use of the Facility for 12 people or less. All Use Times are subject to prior reservation. Minimum of two weeks’ notice is required to secure a reservation for use of the facility for 13 to 49 people. All Fees must be paid a minimum of 48 hours in advance of the event or the event is subject to cancellation.
11. **SET-UP AND TAKE-DOWN**. The Facility will be made available for setup one (1) hour prior to the start of the event and for one hour after the close of the event for take-down.
12. **SEATING**. The Facility includes 10 standard height chairs and 8 bar-height chairs. Event Host must provide any additional seating if needed.
13. **FOOD AND BEVERAGE**. Food and beverages may be provided by the Event Host. Alcoholic beverages are permitted with notice to the CAB and with compliance by the applicant or vendors with any and all County and State permitting and licensing requirements. Additional rules, insurance and/or deposits may be required in the event alcoholic beverages will be served anywhere in the Facility or Facility’s surrounding grounds or parking lot. There is limited space for serving and no cooking facilities are available except a microwave oven. If any open flame device (barbecue grill, propane grill, smoker, etc.) is planned, it must be placed outdoors, safely away from combustible materials. Additional rules, insurance, and/or deposits may be required if an open flame device is to be used.

14. PARKING. The Facility parking lot contains 13 standard vehicle spaces and 1 handicapped space. Additional on-street parking is available. All parking is on a first-come, first-served basis. Parking is limited to the parking lot and street parking unless specific arrangements are made for parking on other adjacent properties. Additional rules, insurance, and/or deposits may be required for use of adjacent properties for parking.

15. CLEAN-UP. Event Host shall be responsible for all cleanup at the close of the event and for returning the Facility to the condition it was in prior to the event. Cleanup shall be completed within one (1) hour of the end of the event. Cleanup includes, but is not limited to, sweeping, vacuuming, cleaning of serving and eating surfaces, removal of trash, debris, food, beverages, seating, tables, displays, audio-visual equipment, decorations, and the like, and restoring all Facility materials to the locations they were in prior to the event. The Refundable Deposit will be returned to the Event Host upon successful completion of cleanup.

16. DAMAGE. The Facility shall be inspected by the CAB and Event Host prior to the opening of the event, and inspected by the CAB and the Event Host at the end of the event. If damage has occurred to any portion of the Facility, including without limitation, the interior of the Facility, the exterior of the Facility, landscaping, irrigation, walkways, and parking areas, the Event Host shall be solely responsible for the cost of repair or replacement of damaged materials.

17. PERMITTING. The Event Host is responsible to obtain any permits needed to hold the event, and for any logistical needs of the event, including but not limited to, traffic control, security, vendor deliveries, trash collection and removal.

18. INSURANCE. All corporate and business users must provide liability insurance in the amounts shown below. The Certificate shall name the Sterling Ranch Community Authority Board as an additional insured. The Insurance Certificate must be supplied to the CAB a minimum of 48 hours prior to the event or the event is subject to cancellation.

Commercial General Liability Policy	\$1,000,000
Automobile Liability, all vehicles, owned or hired	\$1,000,000
Worker's Compensation (if any)	Statutory
Liquor or Host Liquor Liability (if being served)	\$1,000,000

PART I APPLICATION FOR TEMPORARY USE OF THE STERLING RANCH INFORMATION CENTER

Applicant Name			
Address			
Cell #		Bus. Phone #	
Email Address			

USER CATEGORY (check one that applies)

- Employee of the CAB, Sterling Ranch Metropolitan District Nos. 1-7, or Dominion Water and Sanitation District
- Sterling Ranch Development Company, Active Sterling Ranch Homebuilder (for Sterling Ranch business related functions only)
- District Resident
- Non-District Person or Entity

DESCRIPTION OF PROPOSED USE	
REQUESTED DATE AND HOURS OF USE	
NUMBER OF PARTICIPANTS	

FEES	
Refundable Deposit (separate check)	\$0
Non-Refundable Base User Fee	\$0
Non-Refundable User Fee Per Person	\$0
TOTAL	\$0

PART II – RELEASE AND INDEMNIFICATION

The Undersigned desires, and the Sterling Ranch Community Authority Board, an authority and separate legal entity formed pursuant to Section 29-1-203, C.R.S. (the “CAB”) agrees to the temporary use of the Sterling Ranch Information Center (the “Facility”) subject to the terms and conditions as herein defined:

In consideration for use of the Facility, the Undersigned hereby warrants that he or she is over 18 years of age, and for Undersigned, Undersigned’s spouse, minor children, heirs, legal representatives, executors and assigns, agrees as follows:

RELEASE. While fully acknowledging the inherent possible risks in connection with the event, the Undersigned, for itself and its successors and assigns, hereby waives, discharges, and releases the CAB, their successors and assigns, and their owners, directors, officers, employees, managers and agents (collectively the “CAB”), from any claims, causes of action, damages, losses, liabilities and demands of any nature, including without limitation, attorneys’ fees and costs incurred that the Undersigned may have or allege and that arise in connection with the event, whether caused by the negligence of the CAB or otherwise.

INDEMNIFICATION AND AGREEMENT TO DEFEND. The Undersigned also undertakes and agrees to indemnify the CAB against all liabilities, losses and damages of any nature from claims, demands, costs, judgment or other expenses (including without limitation attorneys’ fees and costs incurred) arising out of the Undersigned’s participation in the event. In addition, should the CAB be subject to a lawsuit or other claim for relief arising out of the Undersigned’s participation in the event, the Undersigned agrees to defend and hold harmless from any and all attorneys’ fees and costs incurred in the course of a lawsuit and from any and all liabilities that may result therefrom.

SEVERABILITY. If any provision of this Release and Indemnification or the application thereof to any person or situation, to any extent, shall be held invalid or unenforceable, the remainder of the Release and Indemnification and the application of such provision to persons or situations other than those to which have been held invalid or unenforceable shall not be affected thereby, but shall continue valid and enforceable to the fullest extent permitted by law.

ACKNOWLEDGEMENT. The Undersigned, by signing this Application and Release and Indemnification, hereby acknowledges responsibility for all activities associated with use of the Facility and the event, inclusive of adherence to any and all applicable governmental laws or regulations, including permitting, as well as any vendors or other users for this event, and inclusive of security, traffic control, and associated logistics, and full responsibility for prompt restoration of any damage to site including landscaping or irrigation along with immediate removal of any trash or debris within one (1) hour of the event’s end. Any activity which interferes with adjacent office, retail or public use including but not limited to loudspeakers or blockage of access is not permitted. The Undersigned acknowledges that Undersigned has been provided the CAB’s Rules and Regulations, has read and is familiar with them, and agrees to be bound by their provisions, terms, and conditions, and further agrees to comply with the CAB’s Rules and Regulations and all other local, state and federal laws and regulations at all times during the event and Undersigned’s use of the Facility.

IN WITNESS WHEREOF, the Undersigned, after reading and fully understanding this Release and Indemnification, voluntarily executes this document as of the date written below.

Print Name of Applicant

Signature of Applicant

Company

Title

Date

AUTHORIZATION. The CAB hereby acknowledges that the Applicant is authorized to make temporary use of the Facility, as described herein, upon the terms and conditions specified herein.

CAB Representative Signature

Title

Date

<i>RECEIPT OF FUNDS</i>	<i>CHECK #</i>	<i>AMOUNT</i>	<i>INITIALS</i>
<i>Refundable Deposit - Check Number and Amount</i>	<i>n/a</i>	<i>n/a</i>	
<i>Non-Refundable User Fees – Check Number and Amount</i>	<i>n/a</i>	<i>n/a</i>	